

snorkel

SL30SL

SL26SL



CE

PARTS & SERVICES

MANUAL

Serial Number SL26-01-060105 and after
Serial Number SL30-01-060210 and after

Part Number 514949-200
March 2016

SL26/30SL Series

ENGLISH

When contacting Snorkel for service or parts information, be sure to include the model and serial numbers from the equipment name plate. Should the name plate be missing, the serial number is also stamped on top of the chassis above the front axle pivot.

The serial number is available on nameplate

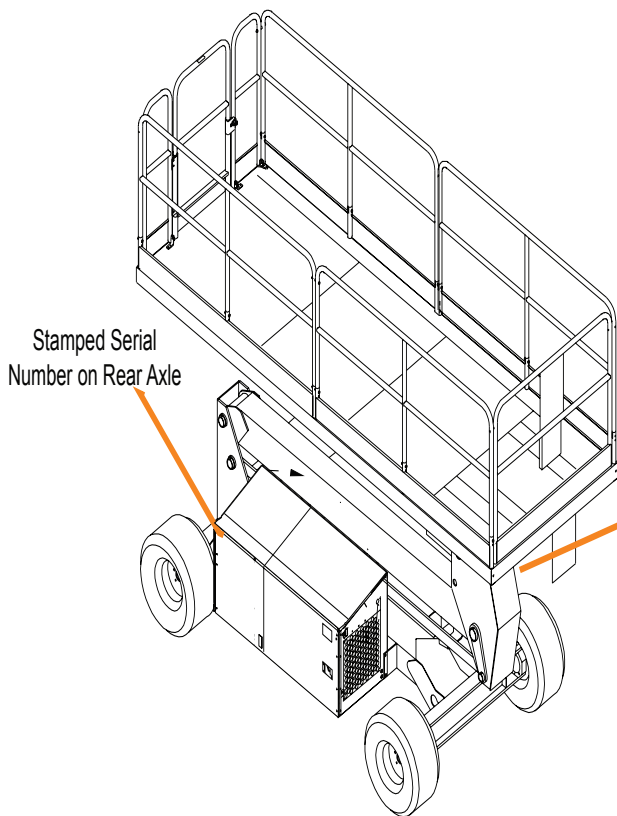

snorkel		Snorkel, Vigo Centre, Birtley Road, Washington, Tyne & Wear, NE33 9DA, U.K.		CE	
MODEL NUMBER	<input type="text"/>	SERIAL NUMBER	<input type="text"/>		
MONTH / YEAR OF MANUFACTURE	<input type="text"/>	SLOPE SENSOR ALARM SETTING			
NON-LOADED MACHINE WEIGHT	<input type="text"/> lbs <input type="text"/> kg	FRONT TO BACK	<input type="text"/> deg	SIDE TO SIDE	<input type="text"/> deg
ENGINE POWERED MODELS	<input type="text"/> hp <input type="text"/> kW	MAXIMUM WHEEL LOAD	<input type="text"/> lbs <input type="text"/> kg	BATTERY POWERED MODELS	DRIVE MOTORS <input type="text"/> V
MAXIMUM OUTRIGGER LOAD	<input type="text"/> lbs <input type="text"/> kg			BATTERIES	<input type="text"/> V <input type="text"/> Ah
MAXIMUM GRADEABILITY	<input type="text"/> %			CHARGER INPUT	<input type="text"/> V
MAXIMUM ALLOWABLE MANUAL FORCE (SIDE PULL)	Indoors <input type="text"/> lbs Outdoors <input type="text"/> N			MAXIMUM ALLOWABLE WIND SPEED	<input type="text"/> mph <input type="text"/> m/s
MAXIMUM PLATFORM HEIGHT	<input type="text"/> ft <input type="text"/> m			MAXIMUM PLATFORM REACH	<input type="text"/> ft <input type="text"/> m
RATED NUMBER OF OCCUPANTS	Indoors <input type="text"/> Outdoors <input type="text"/>			MAXIMUM DRIVE HEIGHT	<input type="text"/> ft <input type="text"/> m
ASSEMBLED IN	<input type="text"/>			MAXIMUM PLATFORM LOAD	<input type="text"/>
CAUTION					
<small>ONLY trained and authorised personnel may operate this machine. Consult the Operation Manual before using this machine. DO NOT make any changes to this machine; any changes made will invalidate the manufactures warranty and may contravene legislation.</small>					
Axle weights with machine in the stowed position.					
STEER AXLE	<input type="text"/> lbs	<input type="text"/> kg			
DRIVE AXLE	<input type="text"/> lbs	<input type="text"/> kg			

USA

TEL: +1 (559)443 6600
FAX: +1 (559)268 2433

Europe

TEL: +44 (0) 1952 200
FAX: +44 (0) 1952 229

www.snorkellifts.com

SL26/30SL SERVICE AND PARTS MANUAL

FOREWORD

This manual is divided into six sections namely;

SECTION 1: INTRODUCTION

General description and machine specifications.

SECTION 2: OPERATION AND SPECIFICATION

Information on how to operate the work platform and how to prepare it for operation.

SECTION 3: SERVICE AND REPAIR

Preventative maintenance and service information.

SECTION 4: TROUBLESHOOTING

Causes and solutions to typical problems.

SECTION 5: SCHEMATICS

Schematics and valve block diagrams with description and location of components.

SECTION 6: ILLUSTRATED PARTS BREAKDOWN

Complete parts list with illustrations.

SPECIAL INFORMATION



NOTE: Provides helpful information.

WORKSHOP PROCEDURES

All information contained in this manual is based on the latest product information available at the time of printing. We reserve the right to make changes at any time without notice.

No part of this publication may be reproduced, stored in retrieval system or transmitted in any form by any means whether electronic, mechanical, photocopying, recording or otherwise without the prior written permission of the publisher. This also includes text, figures and tables.

C A U T I O N

Detailed prescriptions of standard workshop procedures, safety principles and service operations are not included.

Please note that this manual contains warnings and cautions against some specific service methods which could cause personal injury or could damage a machine or make it unsafe.

Please understand that these warnings cannot cover all conceivable ways in which service, whether or not recommended by Snorkel, might be carried out, or of the possible hazardous consequences of each conceivable way, nor could snorkel investigate all such ways.

Anyone using service procedures or tools whether or not recommended by Snorkel must satisfy themselves thoroughly that neither personal safety nor machine safety will be jeopardized.

INTRODUCTION

INTRODUCTION

PURPOSE

The purpose of this service and parts manual is to provide instructions and illustrations for the operation and maintenance of this work platform manufactured by Snorkel.

SCOPE

The manual includes procedures for proper operation, maintenance, adjustment and repair of this product as well as recommended maintenance schedules and troubleshooting.

GENERAL DESCRIPTION

The work platform consists of the platform, controller, elevating assembly, power module, control module and chassis.



PLATFORM

The platform has a reinforced steel floor, 1.1 m (43.5 inches) high guardrails with a mid rail, 152 mm (6 inches) toe boards and an entry gate at the rear of the platform. The guardrails can be folded down for transportation purposes.

Features of the SL26/SL30SL is shown in Figure 1-1.

1. Platform
2. Platform controller assembly
3. Elevating assembly
4. Power module
5. Control module
6. Chassis

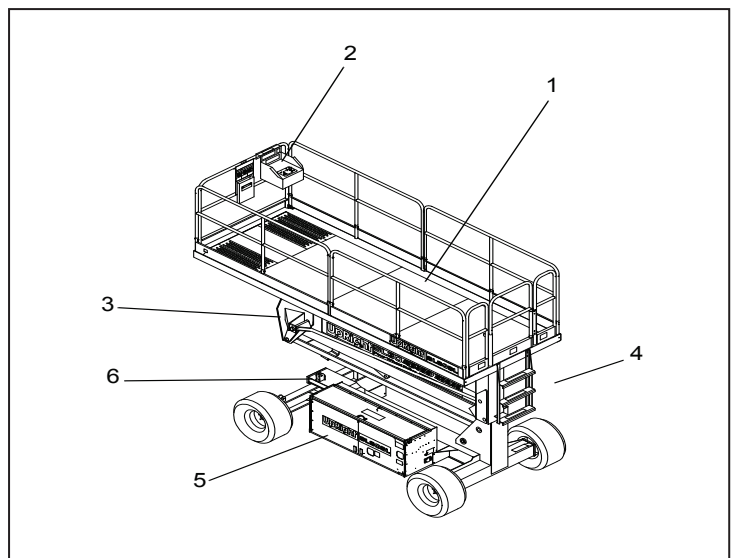

Figure 1-1: Work platform

INTRODUCTION

PLATFORM CONTROLLER

The platform controller contains the controls to operate the machine. It is located at the front of the platform. A complete explanations of control functions can be found in section 2.

ELEVATING ASSEMBLY

The platform is raised and lowered by the elevating assembly. The hydraulic pump driven by the engine, powers the cylinders. Solenoid operated valves control raising and lowering.

CHASSIS

The chassis is a structural frame that supports all the components of the SL26/30SL work platform.

PURPOSE OF EQUIPMENT

The objective of the work platform is to provide a quickly deployable, self propelled, variable height work platform to elevate personnel and materials to overhead work areas.

SPECIAL LIMITATIONS

Travel with the platform raised is limited to a creep speed range.

Elevating of the work platform is limited to firm, even surfaces only. The auto level feature is designed to level the platform in a situation where the ground has no more than a 13 degree slope side to side and 9 degrees front to back. If the platform is not level to within 2 degrees, a warning alarm will sound and platform elevation above approximately 1 m will be disabled.



OPERATION AND SPECIFICATION

SL26/30SL Series

ENGLISH

When contacting Snorkel for service or parts information, be sure to include the model and serial numbers from the equipment name plate. Should the name plate be missing, the serial number is also stamped on top of the chassis above the front axle pivot.

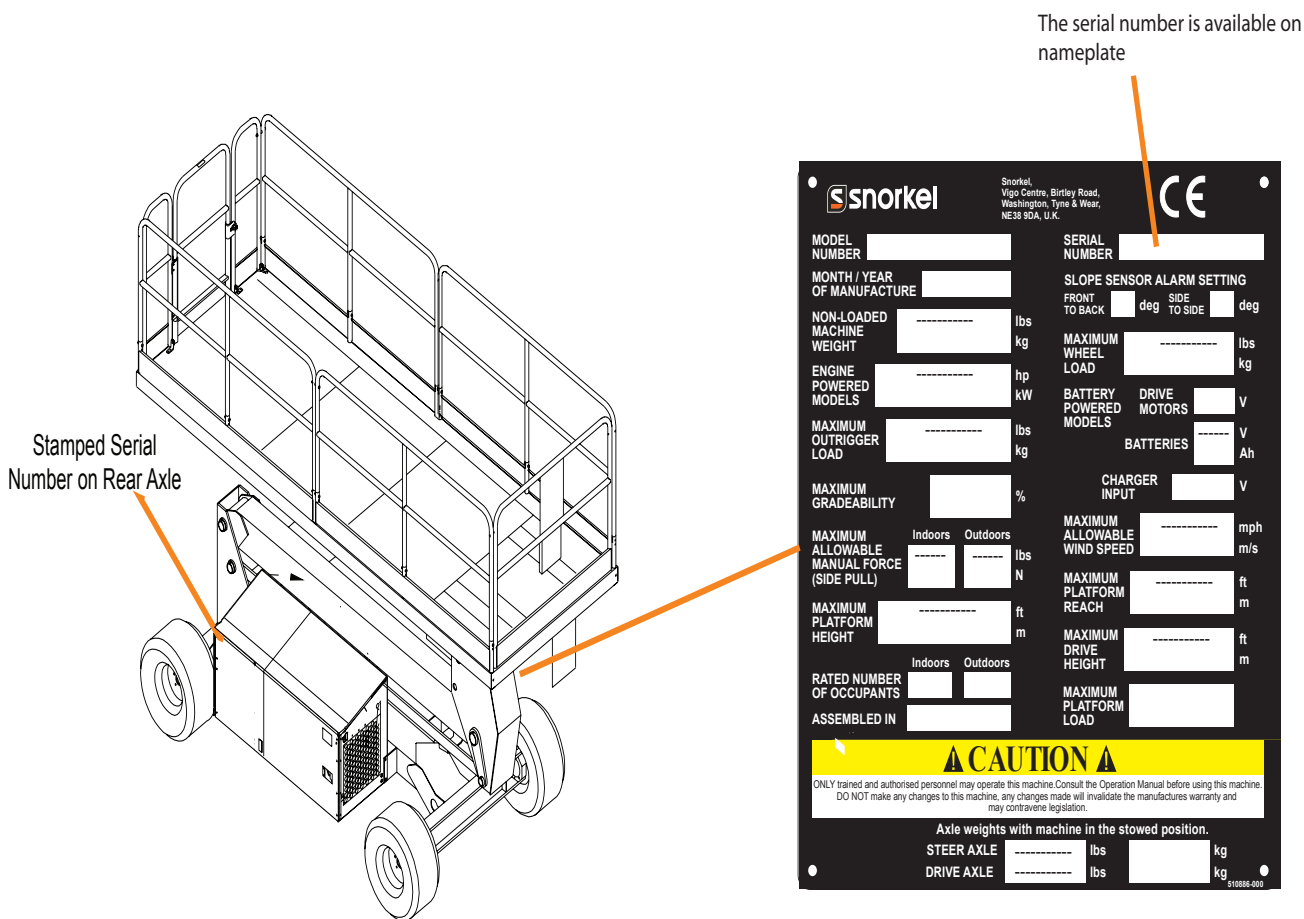

Figure 2-1: Serial number location on SL26/30SL

USA

TEL: +1 (559)443 6600
 FAX: +1 (559)268 2433

Europe

TEL: +44 (0) 1952 200
 FAX: +44 (0) 1952 229

www.snorkellifts.com

SAFETY RULES

WARNING

All personnel shall carefully read, understand and follow all safety rules and operating instructions before operating or performing maintenance on any SNORKEL aerial work platform.

ELECTROCUTION HAZARD TIP OVER HAZARD COLLISION HAZARD FALL HAZARD TRAPPING/CRUSHING HAZARD

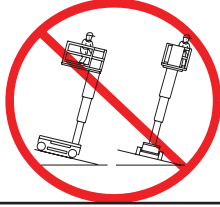

<p>THIS MACHINE IS NOT INSULATED</p>	<p>NEVER ELEVATE THE PLATFORM OR DRIVE THE MACHINE WHILE ELEVATED UNLESS THE MACHINE IS ON A FIRM LEVEL SURFACE</p>	<p>NEVER POSITION THE PLATFORM WITHOUT FIRST CHECKING FOR OVERHEAD OBSTRUCTIONS OR OTHER HAZARDS</p>	<p>NEVER CLIMB, STAND OR SIT ON PLATFORM GUARDRAILS OR MID RAIL</p>	<p>BEWARE OF CRUSHING HAZARD WHEN HOLDING HANDRAILS WHILE THE PLATFORM IS MOVING IN CLOSE PROXIMITY TO OTHER OBJECTS</p>
---	--	---	--	---

- **USE OF THE AERIAL WORK PLATFORM:** This aerial work platform is intended to lift a person or persons and their tools including material needed for a job. The work platform is designed to be used for repair and assembly jobs **ONLY** at overhead work places (ceilings, cranes, roof structures, buildings, etc.).
The use and operation of the aerial work platform as a lifting tool or a crane is **prohibited!**
Climbing up the railing of the platform, standing on or stepping from the platform onto buildings, steel or prefab concrete structures etc is **prohibited!**
NEVER use the machine if damaged, not functioning properly, has damaged or missing decals.
NEVER attach notice boards etc. to the platform as this will increase the wind loading.
- **INSULATION:** The aerial work platform is not insulated. It is imperative to keep a safe distance from live parts or electrical equipment. **DO NOT** get closer than the minimum distance recommended by the "National Regulations".
- **PLATFORM CAPACITY:** Exceeding the specified permissible maximum load is **prohibited!** Refer to platform capacity on page 24 for details.
- **MANUAL FORCE:** **NEVER** exceed the manual force allowed for this machine. Refer to special limitations on page 9 for details.
- **LOAD DISTRIBUTION:** Ensure that all loads are distributed evenly on the platform.
- **SURVEILLANCE:** **NEVER** operate the machine without first surveying the work area for surface hazards such as holes, drop-offs, bumps, curbs or debris and avoiding them.
- **WHEEL LOAD:** **OPERATE** the machine only on surfaces capable of supporting wheel load.
- **WIND SPEED:** **NEVER** operate the machine when the wind speed exceeds the machine's wind speed rating. Refer to the Beaufort scale for details.
- **EMERGENCY STOP:** In case of an emergency, push the **EMERGENCY STOP** switch to de-activate all powered functions.
- **ALARM:** If the alarm sounds while the platform is elevated, **STOP** operation immediately and carefully lower the platform. Move the machine to a firm, level surface.
- **SWING GATE:** Dismantling the entry gate or other railing components is **prohibited!** Always make certain that the entry gate is closed and securely locked.
It is **prohibited** to keep the entry gate in an open position when the platform is raised.
Extending the height of the platform by placing ladders, scaffolds or similar devices on the platform is **prohibited!**
- **SERVICING:** **NEVER** perform service on machine while platform is elevated without blocking the elevating assembly. Refer to "maintenance" for details.
- **INSPECT:** the machine thoroughly for cracked welds, loose or missing hardware, hydraulic leaks, loose wire connections and damaged cables or hoses before usage.
- **DECALS:** **VERIFY** that all labels are in place and legible before using the machine.
- **BATTERIES:** **NEVER** charge batteries near sparks or open flame. Charging batteries emit explosive hydrogen gas.
- **STORAGE:** **AFTER USE**, secure the work platform from unauthorised use by turning the key switch off and removing the key.
- **HARNES:** Harness attachment points are provided on the platform and the manufacturer recommends the usage of a fall restraint harness especially where required by national safety regulations.
Modifications to the aerial work platform are prohibited or permissible only at the approval of the manufacturer.
- **ENVIRONMENTAL TEMPERATURE LIMITATION:** The machine is primarily for use in normal ambient temperatures and conditions ranging between 50C to -20C

SAFETY NOTICE

Harness attachment points are provided in the platform and the manufacturer recommends the usage of a fall restraint harness, especially where required by national safety regulations.

All harness attachment points on SNORKEL vehicles have been tested with a force of 3,650 lbs (16.3 KN) per person.

See below examples of harness attachment points used on SNORKEL vehicles with their corresponding rating;

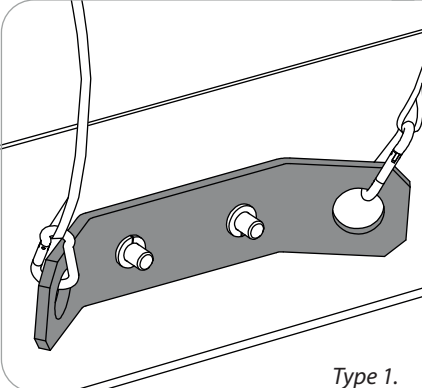
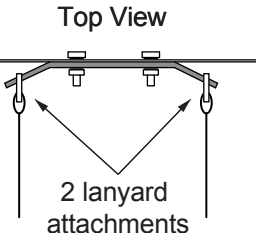
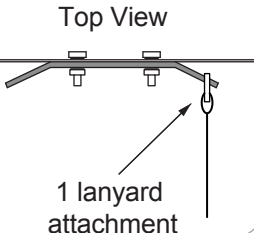
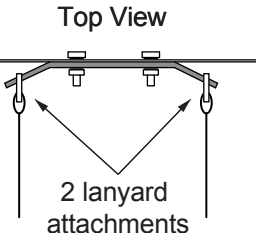
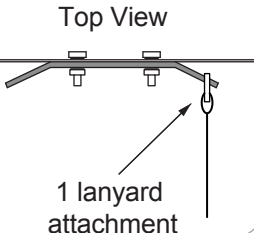
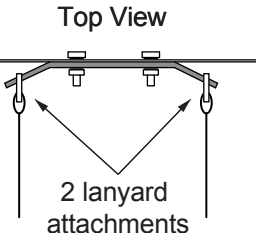
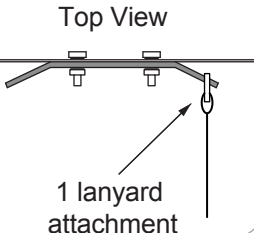
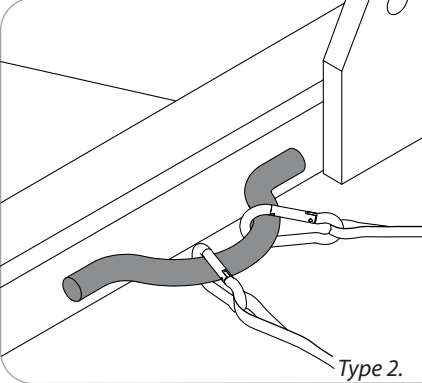
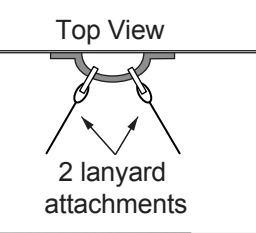
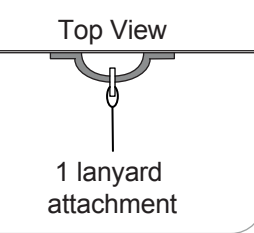
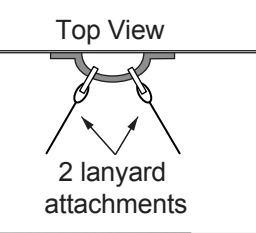
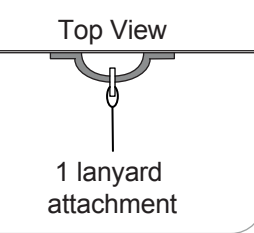
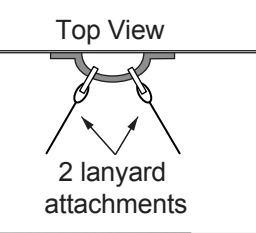
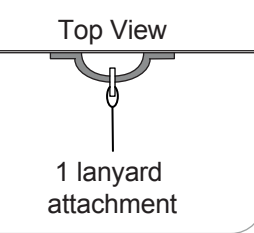
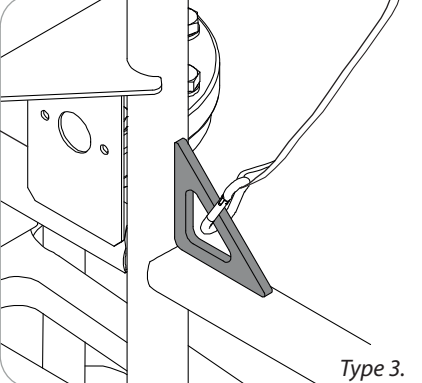
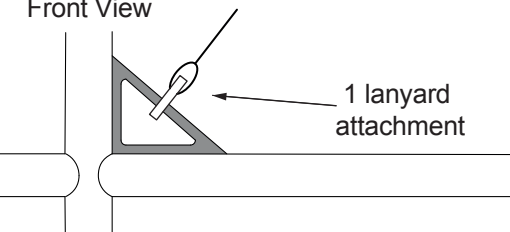
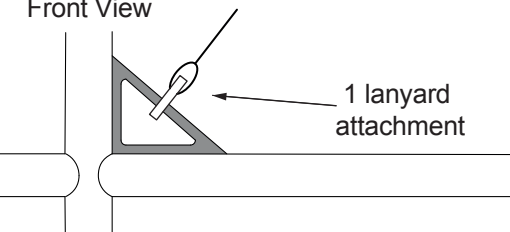
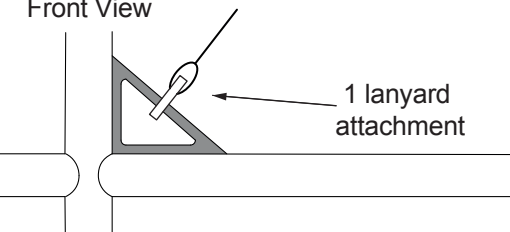
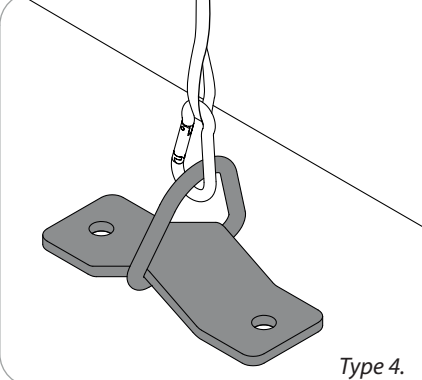
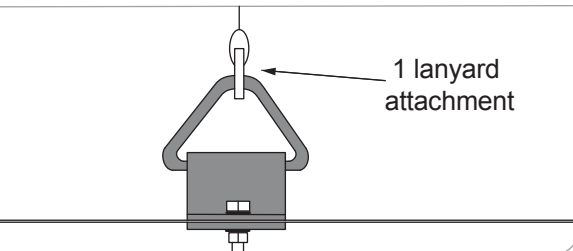
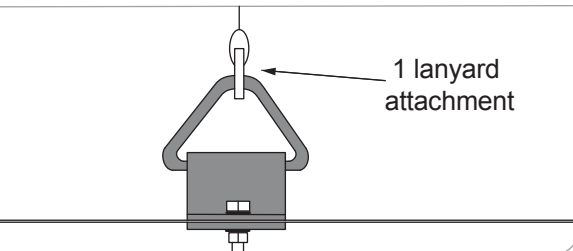
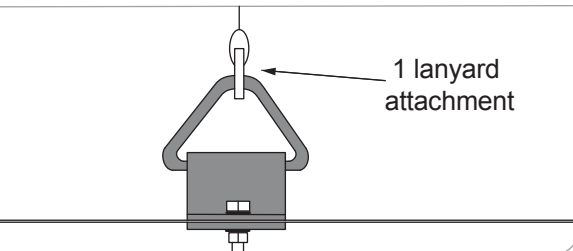
 <p style="text-align: right; margin-top: 10px;"><i>Type 1.</i></p>	<p>Harness attachment point Type 1 is rated for one lanyard attachment per loop as shown in the illustrations depending upon platform occupancy rating (see operators manual & decals).</p> <table border="1" style="width: 100%; border-collapse: collapse;"> <tr> <td style="width: 50%; text-align: center; padding: 5px;"> <p>Top View</p>  <p>2 lanyard attachments</p> </td> <td style="width: 50%; text-align: center; padding: 5px;"> <p>Top View</p>  <p>1 lanyard attachment</p> </td> </tr> </table>	<p>Top View</p>  <p>2 lanyard attachments</p>	<p>Top View</p>  <p>1 lanyard attachment</p>
<p>Top View</p>  <p>2 lanyard attachments</p>	<p>Top View</p>  <p>1 lanyard attachment</p>		
 <p style="text-align: right; margin-top: 10px;"><i>Type 2.</i></p>	<p>Harness attachment point Type 2 is rated for two lanyard attachments per loop as shown in the illustrations depending upon platform occupancy rating (see operators manual & decals).</p> <table border="1" style="width: 100%; border-collapse: collapse;"> <tr> <td style="width: 50%; text-align: center; padding: 5px;"> <p>Top View</p>  <p>2 lanyard attachments</p> </td> <td style="width: 50%; text-align: center; padding: 5px;"> <p>Top View</p>  <p>1 lanyard attachment</p> </td> </tr> </table>	<p>Top View</p>  <p>2 lanyard attachments</p>	<p>Top View</p>  <p>1 lanyard attachment</p>
<p>Top View</p>  <p>2 lanyard attachments</p>	<p>Top View</p>  <p>1 lanyard attachment</p>		
 <p style="text-align: right; margin-top: 10px;"><i>Type 3.</i></p>	<p>Harness attachment point Type 3 is rated for one lanyard attachment per loop as shown in the illustrations depending upon platform occupancy rating (see operators manual & decals).</p> <table border="1" style="width: 100%; border-collapse: collapse;"> <tr> <td style="width: 100%; text-align: center; padding: 5px;"> <p>Front View</p>  <p>1 lanyard attachment</p> </td> </tr> </table>	<p>Front View</p>  <p>1 lanyard attachment</p>	
<p>Front View</p>  <p>1 lanyard attachment</p>			
 <p style="text-align: right; margin-top: 10px;"><i>Type 4.</i></p>	<p>Harness attachment point Type 4 is rated for one lanyard attachment per loop as shown in the illustrations depending upon platform occupancy rating (see operators manual & decals).</p> <table border="1" style="width: 100%; border-collapse: collapse;"> <tr> <td style="width: 100%; text-align: center; padding: 5px;">  <p>1 lanyard attachment</p> </td> </tr> </table>	 <p>1 lanyard attachment</p>	
 <p>1 lanyard attachment</p>			

NOTE: There can be more harness attachment points per machine than the maximum number of occupants allowed in a platform. Refer to the platform decal & specifications table listed in the operators manual for the correct occupancy rating before use.

SAFETY NOTICE

NOTE:

1. To bypass any safety equipment is **prohibited** and presents a danger for the person/persons on the aerial work platform and in its working range.
2. Modification to the aerial work platform is **prohibited** or permissible only at the approval of Snorkel.
3. The driving of MEWP'S on the public highway is subject to national traffic regulations.
4. It is important to ensure that the machine meets the requirements of stability during use, transportation, assembly, dismantling when out of service, testing or foreseeable breakdowns.
5. Never use a machine that is damaged or not functioning properly. Verify that all labels are in place and legible before using.

INTRODUCTION	2-6
GENERAL DESCRIPTION	2-6
SPECIAL LIMITATIONS	2-7
SPECIAL LIMITATIONS	2-7
PLATFORM CAPACITY	2-7
MANUAL FORCE	2-7
BEAUFORT SCALE	2-7
LIFT OVERLOAD ALARM	2-8
CONTROLS/PRE-OPERATION	2-9
PLATFORM CONTROLS AND INDICATORS	2-9
CHASSIS CONTROLS AND INDICATORS	2-9
PRE-OPERATION SAFETY INSPECTION	2-10
SYSTEM FUNCTION INSPECTION	2-11
OPERATION	2-12
STARTING THE MACHINE	2-12
STEERING	2-12
ELEVATING THE PLATFORM	2-12
LOWERING THE PLATFORM	2-12
TRAVEL WITH THE PLATFORM LOWERED	2-12
TRAVEL WITH THE PLATFORM ELEVATED	2-13
LEVELLING THE PLATFORM	2-13
HOUR METER	2-13
PLATFORM EXTENSION (SL26 SPEED LEVEL ONLY)	2-14
PLATFORM RETRACTION(SL26 SPEED LEVEL ONLY)	2-14
FOLD DOWN GUARDRAILS	2-14
FOLD DOWN PROCEDURE	2-14
UNFOLD PROCEDURE	2-15
EMERGENCY PROCEDURE	2-16
TOWING OR WINCHING	2-16
BRAKE RELEASE PUMP	2-16
EMERGENCY LOWERING	2-17
TRANSPORTATION	2-18
PREPARATION FOR SHIPMENT	2-18
LIFTING BY CRANE	2-18
DRIVING OR WINCHING ONTO A TRACK OR TRAILER	2-18
AFTER USE EACH DAY	2-18
MAINTENANCE	2-19
BLOCKING THE ELEVATING ASSEMBLY	2-19
INSTALLATION	2-19
REMOVAL	2-19
BATTERY MAINTENANCE (FOR MAINTENANCE BATTERIES ONLY)	2-19
BATTERY CHARGING	2-19
INSPECTION AND MAINTENANCE	2-20
DAILY PREVENTATIVE MAINTENANCE SCHEDULE	2-21
SPECIFICATIONS	2-22
SPECIFICATIONS	2-23
WASTE REMOVAL AND DISPOSAL	2-24

INTRODUCTION

INTRODUCTION

This manual covers the operation of the SL26/30 Speed level series Self-Propelled Work Platforms. This manual must be stored on the machine at all times.

GENERAL DESCRIPTION

1. Platform
2. Elevating Assembly
3. Chassis
4. Power Module
5. Control Module
6. Platform Controls
7. Manual Case
8. Chassis Controls
9. Hydraulic Fluid Reservoir

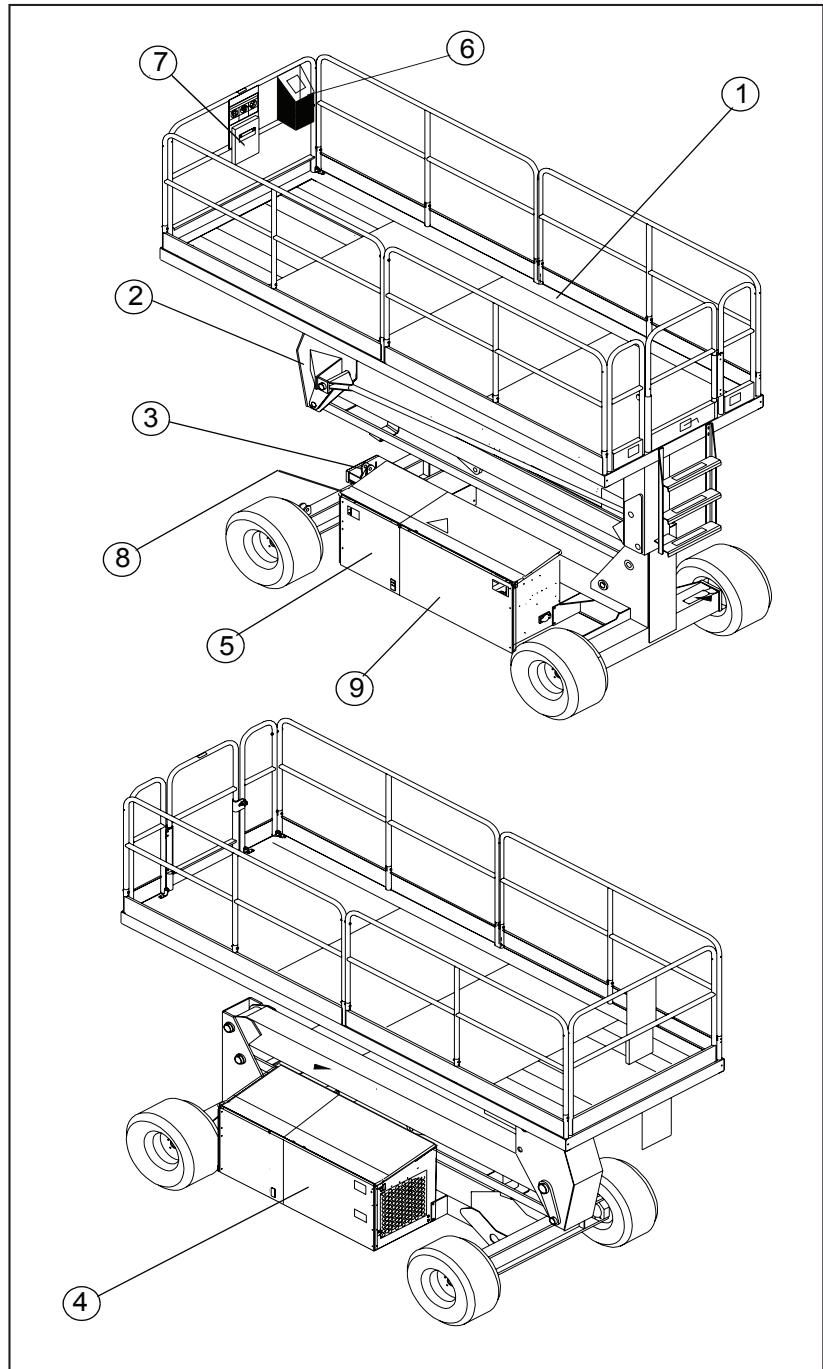

Figure 2-2: SL26/30 SL series

SPECIAL LIMITATIONS

Travel with platform raised is limited to a maximum speed of 0.8 km/h (0.5 mph). Elevating the work platform is limited to firm surfaces only.

! D A N G E R !

*The elevating function shall **ONLY** be used when the work platform is levelled and on a firm surface. The work platform is designed to be driven over uneven, rough or soft terrain however, great care is required when traversing adverse terrain. Appropriate speeds should always be used.*

PLATFORM CAPACITY

The platform capacity for the machine including occupants is determined by model and options. This is listed under “specifications” on page 24.

! D A N G E R !

***DO NOT** exceed the maximum platform capacity or the platform occupancy limits for this machine.*

MANUAL FORCE

Manual force is the force applied by the occupants to objects such as walls or other structures outside the work platform. The maximum allowable manual force is limited to 200 N (45 lbs.) of force per occupant with a maximum of 400 N (90 lbs.) for two or more occupants.

! D A N G E R !

***DO NOT** exceed the maximum amount of manual force for this machine.*

BEAUFORT SCALE

Beaufort Scale	m/Sec	Ground Conditions
3	3.5-5	Leaves and small twigs in constant motion; wind extends light flag.
4	6-8	Raises dust and loose paper; small branches are moved
5	9-10	Small trees in leaf begin to sway; crested wavelets on inland waterways.
6	11-13	Large branches in motion; umbrellas used with difficulty.
7	14-17	Whole trees in motion; inconvenience felt when walking against wind.
8	18-21	Breaks twigs off trees; generally impedes progress.
9	22-24	Slight structural damage occurs (chimney pots and slates removed)

Table 2-1: Beaufort scale

Never operate the machine when wind speed exceeds 12.5 m/s (28 mph) as indicated on the Beaufort scale.

SPECIAL LIMITATIONS

LIFT OVERLOAD ALARM

If a load equivalent to 100% of safe working load is lifted, the overload LED's on the platform and ground control box will illuminate. However, If a load which is greater than the safe working load is placed on the platform, all machine functions will cease to operate and a warning alarm will sound.

To operate the machine, a load equal to or less than the safe working load must be placed on the platform. To re-start the machine functions, push down the emergency stop button to re-set and then release it to restore power.

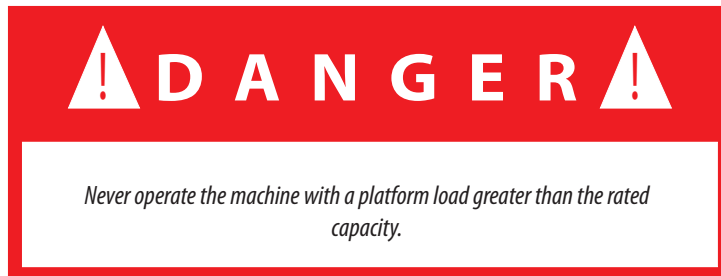

PLATFORM CONTROLS AND INDICATORS

1. Emergency stop button
2. Horn button
3. OFF/ON Engine start switch
4. Glow plug button
5. Engine warning LED
6. Low speed drive switch
7. Low speed drive enabled LED
8. Medium speed drive switch
9. Medium speed drive enabled LED
10. High speed drive switch
11. High speed drive enabled LED
12. Lift/Lower Switch
13. Lift/Lower enabled LED
14. Auto level switch
15. Platform tilt-steady red
axle tilt - flashing red
16. Overload LED
17. Joystick

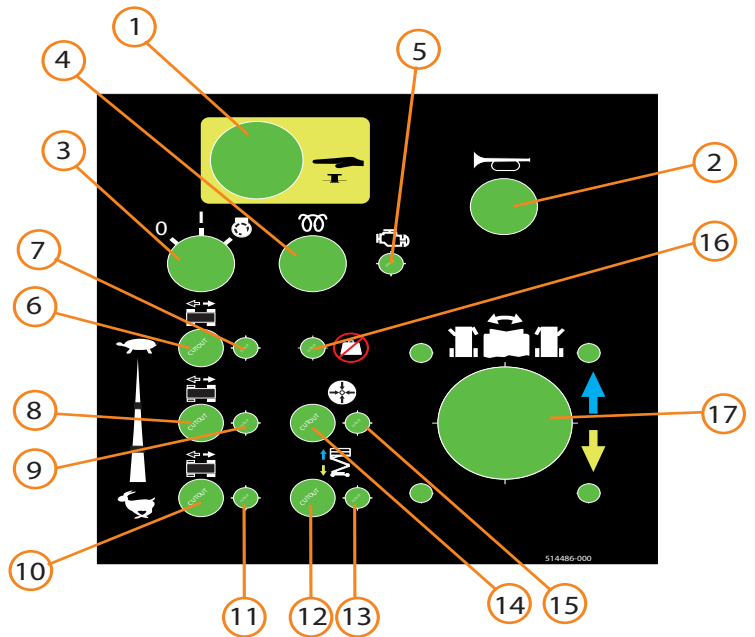

Figure 2-3: Platform controls and indicator locations

CHASSIS CONTROLS AND INDICATORS

1. Emergency stop button
2. Overload LED
3. Keyswitch: Platform/OFF/Chassis
4. Lift/Lower Switch
5. Enable Switch
6. Engine start button
7. Glow plug button
8. Display

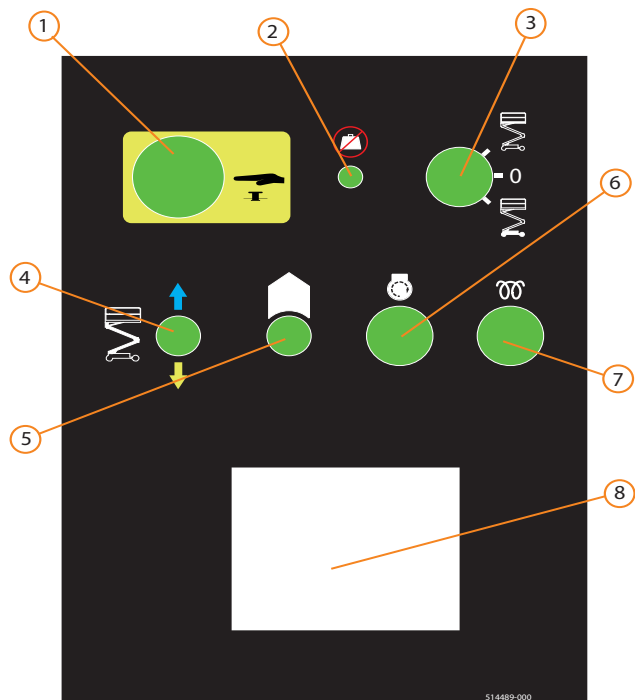

Figure 2-4: Chassis controls and indicator locations

CONTROLS/PRE-OPERATION

PRE-OPERATION SAFETY INSPECTION

NOTE: Carefully read, understand and follow all safety rules, operating instructions, labels and National Safety Instructions/Requirements. Perform the following steps each day before use.

1. Open modules and inspect for damage, fluid leaks or missing parts.
2. ➤ Check the level of the hydraulic fluid with the platform fully lowered.
 - The hydraulic reservoir is located in the control module.
 - The fluid level must be between the minimum and maximum lines.
 - Add hydraulic fluid if necessary.
3. Check that the fluid level in the starter battery is correct.
4. ➤ Check the level of the diesel fuel with the engine switched off.
 - The fuel tank is located in the power module.
 - Add fuel as required.
5. Check that all guard rails are in place and all fasteners are properly tightened.
6. Inspect the machine thoroughly for cracked welds and structural damage, loose or missing hardware, hydraulic leaks, damaged control cables, loose wire connections and wheel bolts.



Figure 2-5: Hydraulic tank

NOTE: Check decal located on tank for Hydraulic fluid Specifications (refer to figure 2-5). Adding fluids of a different specification may cause operational problems.

! CAUTION !

Not all hydraulic fluid is suitable for use in the hydraulic system. The use of hydraulic fluid which is not specified may increase component wear.

ONLY use hydraulic fluid as recommended.

To make the best use of power and performance from the engine, it is important to use fuel of the correct quality. The recommended fuel for the SL machines is diesel fuel with a minimum Cetane number of 45.

Refer to specifications on page 2-22 for suitable fuel information.

SYSTEM FUNCTION INSPECTION

Refer to figure 2-3 and 2-4 on page 2-9 for the locations of various controls and indicators.

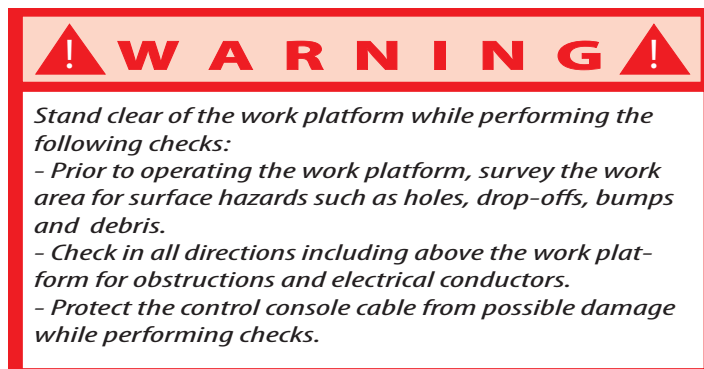

1. If necessary, move the machine to an unobstructed area to allow for full elevation.
2. Switch the battery isolator ON.
3. Twist the chassis emergency stop switch to the ON position.
4. Twist the platform emergency stop switch to the ON position.
5. Visually inspect;
 - The elevating assembly
 - Lift cylinders
 - Cables and hoses for cracked welds and structural damage
 - Loose hardware
 - Hydraulic leaks, loose wire connections and erratic operation.
 - Check for missing or loose parts.
6. Turn the key switch to the chassis control position
7. Start the engine by pressing the engine start button.

NOTE: If the engine is cold, you may need to press the glow plug button for a few seconds before starting the engine.

8. Raise and hold the enable toggle switch and then raise and hold the lift/lower switch to fully elevate the platform.
9. Partially lower the platform by raising the enable switch and lowering the lift/lower switch.
10. Open the Emergency lowering valve (refer to figure 2-8) by pulling the knob out to check for proper operation. When the platform is lowered, release the knob.
11. Push the chassis emergency stop switch to check for proper operation. All machine functions should be disabled. Twist the chassis emergency stop switch to resume.
12. Check that the route is clear of obstacles (persons, obstructions, holes and drop-offs, bumps and debris), is level and capable of supporting the wheel loads.
13. Turn keyswitch to upper control position.
14. Mount the platform and properly close the entrance.
15. Start the engine from the platform controls.
16. Select low speed drive mode.

NOTE: Use both high and low drive (if applicable) when performing the following steps.

17. While engaging the safety interlock trigger, move the joystick forward then reverse to check for speed control.
18. Push the steering switch right then left to check for steering control.
19. Repeat for medium and high speed drive.
20. Select LIFT mode. Grasp the joystick engaging the safety interlock trigger and push it forward to check platform lift controls. Raise the platform to full elevation.
21. Pull back on the joystick. The platform should descend and the audible lowering alarm should sound.
22. Push the platform emergency stop switch to check for proper operation. All machine functions should be disabled. Pull out the platform emergency stop switch to resume.

OPERATION

Before operating the work platform, ensure that the pre-operation safety inspection has been completed and that any deficiencies have been corrected. **Never operate a damaged or malfunctioning machine.** The operator must be thoroughly trained on this machine.

STARTING THE MACHINE

1. Turn the key switch to the platform position.
2. Mount the platform and properly close the entrance.
3. If the engine is cold, press down and hold the “glow plug button” for approximately 5 seconds.
4. Select engine start and hold until the engine is running.

STEERING

NOTE: Steering is not automatically centred. wheels must be returned to straight ahead position by operating the steering switch.

1. Select a DRIVE mode.
2.
 - While engaging the safety interlock trigger, push the steering switch to right or left to turn the wheels in the desired direction.
 - Observe the tyres while manoeuvring the machine to ensure it moves in the correct direction.

ELEVATING THE PLATFORM

NOTE: If the chassis inclination limit is exceeded and the platform is elevated above approximately 2 m (6 ft), the tilt alarm will sound and the machine will not lift or drive. If the tilt alarm sounds, the platform must first be fully lowered and then approximately elevated to 600 mm (2 ft). Press and hold the auto level switch and then engage the safety interlock trigger until the tilt LED extinguishes. If the platform is not levelled correctly, the tilt alarm will continue to sound and the lift functions will be cut off.

1. Check clearances below and to the sides of the platform.
2. Select lift mode.
3. While engaging the safety interlock trigger, push the joystick forward.

LOWERING THE PLATFORM

1. Check clearances below and to the sides of the platform.
2. Select LIFT mode.
3. Engage the safety interlock trigger and pull back on the joystick to lower the platform.

TRAVEL WITH THE PLATFORM LOWERED

1. Check that the route is clear of obstacles (persons, obstructions, holes, drop-offs, bumps and debris) and capable of supporting wheel load.
2. Ensure that the chassis emergency stop switch is ON (pulled out).
3. Mount the platform and properly close the entrance.
4. Check clearances above below and to the sides of the platform.
5. Twist the platform emergency stop switch out to the ON position.
6. Start the machine and select a DRIVE mode.

NOTE: Choose between standard drive, high, low and extra torque depending on the gradient.

7. High speed select option on the platform controls is for 2-wheel drive only. Low speed maximum torque select option is for 4-wheel drive only.
8. High speed should only be used to cover longer distances over firm level ground. It is not intended to be used for precise manoeuvring or positioning.
9. Engage the safety interlock trigger and move the joystick to forward or reverse to travel in the desired direction. The speed of the machine will vary depending on how far from centre the joystick is moved.

TRAVEL WITH THE PLATFORM ELEVATED

NOTE: The machine will travel at reduced speed when the platform is elevated.

1. Check that the route is clear of obstacles (persons, obstructions, holes, drop-offs, bumps and debris) and capable of supporting the wheel load.
2. Check clearances above, below and to the sides of the platform.
3. Select DRIVE mode.
4. Engage the safety interlock trigger on the joystick and move forward or reverse to travel in the desired direction. The speed of the machine will vary depending on how far from centre the joystick is moved.
5. If the machine is not level, the tilt alarm will sound and the machine will not lift or drive. If the tilt alarm sounds, the platform must be lowered and the platform levelled (see below) before attempting to re-elevate the platform.

LEVELLING THE PLATFORM

The auto level feature is designed to level the platform in a situation where the ground has no more than a 13 degree slope side to side and 9 degrees front and back. If the slope is greater than 13 degrees side to side and 9 degrees front and back, the “auto level” feature will not function. The tilt alarm will continue to sound until the platform is level.

1. Check that the route is clear of obstacles (persons, obstructions, holes, drop-offs, bumps and debris) and capable of supporting wheel load.
2. Check clearances above, below and to the sides of the platform.
3. Elevate the platform approximately 600 mm (2 ft).
4. Press and hold the “auto level” and engage the safety interlock trigger until the platform is level, the tilt alarm is silenced and the tilt LED extinguished.
5. The machine can now be driven within the limits of the tilt sensor. If the terrain changes, the machine will stop and the platform must be lowered and re-levelled.

NOTE: This machine has a floating axle which locks when elevated above approximately 2 m (6 ft). If the machine is elevated and the ground slope causes the floating axle to be out of level when compared to the fixed axle, drive will be disabled. This will be indicated by the tilt LED flashing red. In this event, lower the platform below 2 m (6 ft) to enable drive.

HOUR METER

The runtime hours are displayed on the chassis control panel.

OPERATION

PLATFORM EXTENSION (SL26 SPEED LEVEL ONLY)

The platform can be extended and securely locked into position. Use the following procedure to extend the platform:

1. Enter the platform and close the gate.



2. While facing the front of the platform, unlock the LH and RH handles on the extension platform. Using the handles, slide the extension platform out. Ensure that the LH and RH are locked securely in place.
3. Try to move the rails back and forth to make sure the platform extension is locked in place.

PLATFORM RETRACTION(SL26 SPEED LEVEL ONLY)

1. Enter the platform and close the gate.

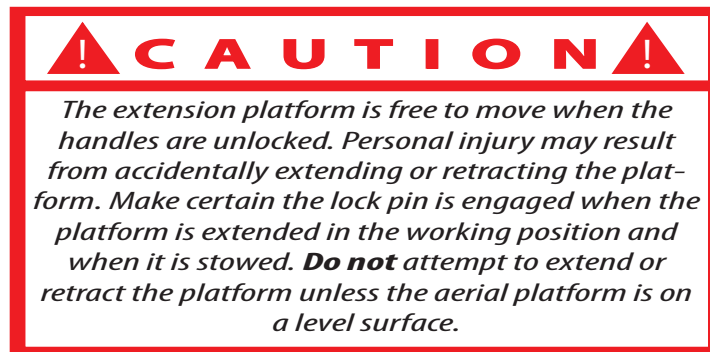

2. While facing the front of the platform, unlock the LH and RH handles on the extension platform. Using the handles, slide the extension platform in. Ensure that the LH and RH are locked securely in place.
3. Try to move the rails back and forth to make sure the platform extension is locked in place.

FOLD DOWN GUARDRAILS

This procedure is for the purpose of transportation. Guardrails must be returned to the upright position (safe working position) before using the machine.

FOLD DOWN PROCEDURE

1. Retract extension platform by releasing securing pins and sliding extension platform into locking position.
2. Unhook the controller from the side guardrail and place it on the floor of the platform.
3. Starting at the front of the platform, remove nuts, bolts and washers from the top of the front guardrail. Fold the front guardrail down onto the platform.

4. Close the latch gate.
5. Remove nuts, bolts and washers from the top of the rear guardrail. Fold the rear guardrail down onto the platform being careful to keep latched at all times.
6. Remove nuts, bolts and washers from the top of the side guardrails. Lift up and fold one side guardrail in resting it on the deck. Repeat with other side guardrails.

UNFOLD PROCEDURE

1. Raise side guardrails, making sure each is pushed down to secure the guardrail in the vertical position.
2. Install bolts, washers and nuts between the side guardrails, tighten securely.
3. Raise rear guardrail assembly, aligning holes and install bolts, washers and nuts. Tighten securely.

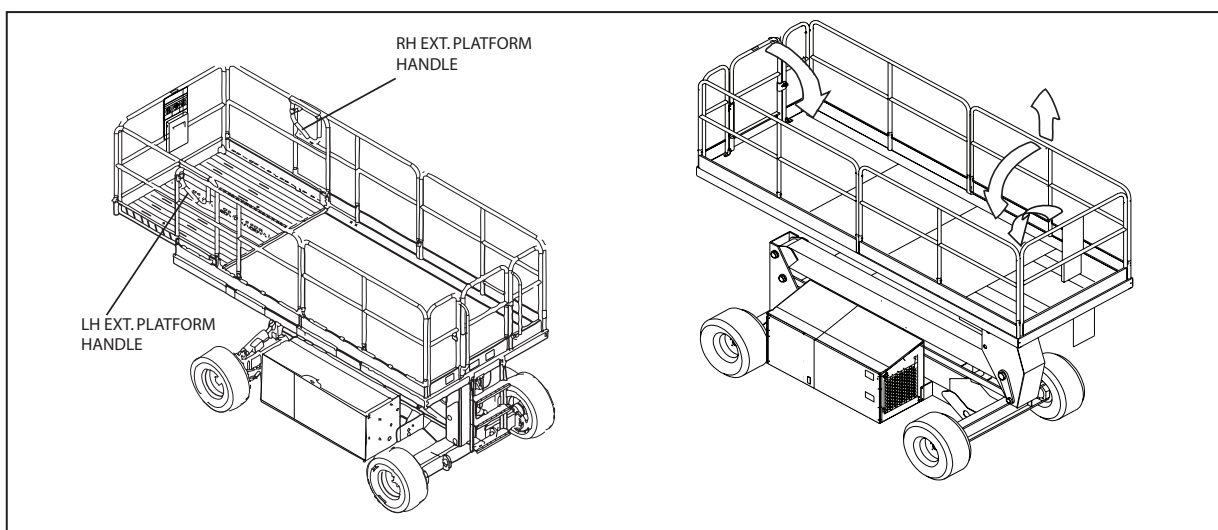

Figure 2-6: A view of the platform handle locations and fold directions.

EMERGENCY PROCEDURE

TOWING OR WINCHING

Perform the following action only when the machine will not operate under its own power and it is necessary to move the machine or when winching onto a transport vehicle (Refer to “Transporting the work platform” on page 2-18).

! CAUTION !

***DO NOT** tow or winch the machine faster than 0.3 m/s (1 ft/s). Faster speeds will damage drive components and void the warranty.*

BRAKE RELEASE PUMP

Perform the following only when the machine will not operate under its own power and it is necessary to move the machine or when towing the machine up a grade or onto a trailer to transport.

1. Open the needle valve by turning the screw anti-clockwise. This allows the wheels to freewheel.
2. Pump the brake release pump until the parking brake is released.
3. The machine will be able to roll when pushed or pulled.
4. Be sure to close the needle valve and screw in the PC3 valve with an allen key after undoing the locknut. This will release the brake pressure. Once the brakes have been re-applied, return PC3 valve to its original configuration by fully unscrewing. Finally tighten the locknut.

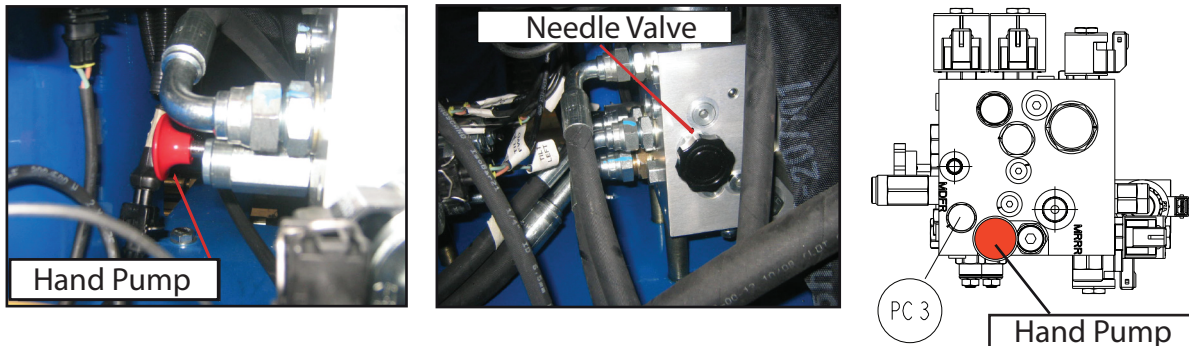

Figure 2-7: A view of the hand pump and needle valve locations.

! W A R N I N G !

Never tow faster than 0.3 m/s (1 ft/s). Never operate the work platform with the parking brakes released. Serious injury or damage could result.

EMERGENCY LOWERING

! W A R N I N G !

*If the platform should fail to lower, **NEVER** climb down the elevating assembly. Stand clear of the elevating assembly while operating the emergency lowering valve knob.*

The emergency lowering valve for the SL machine is located on the module side as shown in figure 2-8.

1. Open the emergency lowering valve by pulling and holding the handle.
2. To close, release the handle.

NOTE: The platform will not elevate if the emergency lowering valve is open.



Figure 2-8: Emergency Lowering handle.

TRANSPORTATION

PREPARATION FOR SHIPMENT

1. Fully lower the platform.
2. Turn batteries OFF with master switch.

LIFTING BY CRANE

1. Secure straps to chassis tie down/lifting lugs only.
2. Place the platform onto the transport vehicle in transport position.
3. Chock the wheels.
4. Secure the work platform to the transport vehicle with chains or straps of adequate load capacity attached to the chassis tie down/lifting lugs.

DRIVING OR WINCHING ONTO A TRACK OR TRAILER

NOTE: Do not winch faster than 0.3 m/s (1 ft/s)

1. Move the machine onto the truck or trailer using the following procedure:
 - To drive the machine onto the transport vehicle;
 - Move the work platform up the ramp and into transport position.
 - Set the wheels straight and turn off the machine.
 - Chock the wheels.
 - To winch the machine onto the transport vehicle;
 - Move the work platform up to the ramp.
 - Attach the winch cable to the tie down/lifting lugs.
 - Release the parking brakes. Refer to towing or winching on page 2-16.
 - Winch the platform into transport position.
 - Chock the wheels.
2. Secure the work platform to the transport vehicle with chains or straps of adequate load capacity attached to the chassis tie down/lifting lugs.



AFTER USE EACH DAY

1. Ensure that the platform is fully lowered.
2. Park the machine on a firm level surface, preferably under cover, secure against vandals, children and unauthorised operation.
3. Turn the chassis key switch to OFF and remove the key to prevent unauthorised operation.
4. Turn batteries OFF with master switch.

! WARNING !

*Never perform service while the platform is elevated without first blocking the elevating assembly. **DO NOT** stand in the elevating assembly area while deploying or removing the jackstand.*

BLOCKING THE ELEVATING ASSEMBLY

INSTALLATION

1. Park the work platform on firm, level ground and leave the engine running.
2. Ensure the chassis emergency stop button is twisted to the ON position.
3. Press and hold the chassis ENABLE and then LIFT switches to elevate the platform approximately 305 mm (12 inches).
4. Place a jackstand with a minimum rating of 2000 kg (4000 lbs.) between the lower mast and chassis just behind the front axle.
5. Press and hold the chassis ENABLE and then DESCEND switches to lower the platform until jackstand is secured tightly between the lower mast and chassis.

REMOVAL

1. Press and hold the chassis ENABLE and then LIFT switches to elevate the platform until the jackstand can be removed.
2. Remove the jackstand.
3. Press and hold the Chassis ENABLE and the DESCEND switches to completely lower the platform.

BATTERY MAINTENANCE (FOR MAINTENANCE BATTERIES ONLY)

! WARNING !

*Hazard of explosive gas mixture. Keep sparks, flame and smoking material away from batteries.
Always wear safety glasses when working near batteries.
Battery fluid is highly corrosive. Thoroughly rinse away any spilled fluid with clean water.
Always replace batteries with Snorkel batteries or manufacturer approved replacements.*

- Check the battery fluid level daily, especially if the work platform is being used in a warm, dry climate.
- If electrolyte level is lower than 10mm (3/8 in.) above the plates, add distilled water only. DO NOT use tap water with high mineral content as it will shorten battery life.
- Keep the terminals and tops of the batteries clean.
- Refer to the service manual to extend battery life and for complete service instructions.

BATTERY CHARGING

The battery charges while the engine is running.

INSPECTION AND MAINTENANCE

The complete inspection consists of periodic visual and operational checks along with periodic minor adjustments that assure proper performance. Daily inspection will prevent abnormal wear and prolong the life of all systems. The inspection and maintenance schedule should be performed by personnel who are trained and familiar with mechanical and electrical procedures.

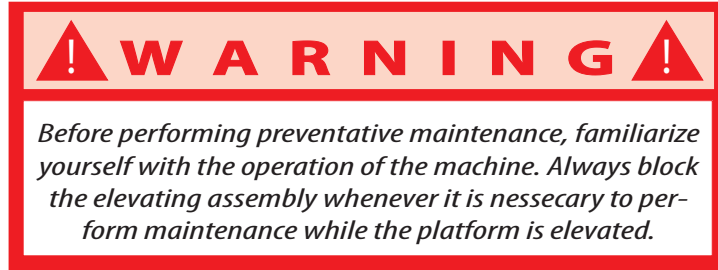

The daily preventative maintenance checklist has been designed for machine service and maintenance. Photocopy the checklist page and use the checklist when inspecting the machine.

INSPECTION AND MAINTENANCE

DAILY PREVENTATIVE MAINTENANCE SCHEDULE

MAINTENANCE TABLE KEY

Y = Yes/Acceptable
N = No/Not Acceptable
R = Repaired/Acceptable

PREVENTATIVE MAINTENANCE REPORT

Date: _____
 Owner: _____
 Model #: _____
 Serial #: _____
 Serviced by: _____

COMPONENT	INSPECTION OR SERVICES	Y	N	R
Operator's Manual	Check that the operators manual is in the manual holder and all pages are intact and readable			
Labels & Decals	Check that labels and decals are in place, intact and readable			
Entire Unit	Perform pre-operation inspection			
	Check for and repair any damage			
Electrical system	Check cables and wiring harness condition (No wear or physical damage)			
Battery System	Check electrolyte level			
	Check battery cable condition			
	Check terminals are clean and connectors are tight			
	Check charger condition and operation			
	Charge batteries			
Hydraulic fluid	Check oil level			
Hydraulic system	Check all fittings are tight and there are no leaks			
Drive motors	Check for operation and leaks			
Hydraulic pump	Check fittings are secure and there are no leaks			
Emergency lowering	Check emergency lowering correctly (See emergency lowering procedure)			
Controller	Check condition and operation			
Platform deck and rails	Check fasteners are in place, correctly tightened and not damaged			
	Check the structure and welds for damage, deformation, corrosion and cracks			
	Check condition of deck (no damage, deformation, corrosion or cracks)			
	Check entry gate closure functions correctly			

COMPONENT	INSPECTION OR SERVICES	Y	N	R
Elevating assembly	Inspect for external damage, dents, loose rivets or cracks.			
	Check the structure and welds for damage, deformation, corrosion and cracks			
Chassis	Check cables for pinch or rubbing points			
	Check the structure and welds for damage, deformation, corrosion and cracks			
Lift Cylinders	Check for leaks			
Wheels	Check for loose components			
	Check for damage to tyres			
Harness anchor point	Check fasteners are secure			
	Check for damage, deformation, corrosion and cracks			
System function inspection	Conduct system function inspection (see system function inspection procedure)			
Emergency stops	Check that the emergency stop button on the basket panels operates correctly			
	Check that the emergency stop button on the ground control panel operates correctly			
Brakes	Check that the brakes operate correctly			
Horn	Check that the horn sounds when activated			
Controller and Sensors	Check that the level sensor functions correctly (drive and platform raise functions are disabled and only platform lowering enabled) when the platform inclination exceeds the specification inclination value.			
	Check full drive speed range is enabled when the platform is stowed.			
	Check that only reduced drive speed range is enabled when the platform is elevated.			

Table 2-2: Daily preventative maintenance checklist

*** NOTE: Use ISO #46 during summer and ISO #32 during winter**

SPECIFICATIONS

ITEM	SL26SL	SL30SL
PLATFORM SIZE (INSIDE TOEBOARDS)		
STANDARD	1.71 m x 3.66 m [67.5 in. x 144 in.]	1.71 m x 4.22 m [67.5 in. x 166.5 in.]
SLIDE OUT DECK EXTENDED	1.71 m x 4.55 m [67.5 in. x 179 in.]	N/A
MAXIMUM PLATFORM CAPACITY		
STANDARD	680 kg [1500 lbs.]	590 kg [1300 lbs.]
W/EXTENSION	680 kg [1500 lbs.]	N/A
On EXTENSION	225 kg [496 lbs.]	N/A
MAXIMUM NUMBER OF OCCUPANTS		
STANDARD	2 PEOPLE (WIND SPEED 12.5 m/s)	5 PEOPLE (WIND SPEED 12.5 m/s)
On EXTENSION	2 PEOPLE (WIND SPEED 12.5 m/s)	N/A
HEIGHT		
WORKING HEIGHT	9.75 m [32 ft.]	10.85 m [35.6 ft.]
MAXIMUM PLATFORM HEIGHT	7.90 m [26 ft.]	9.0 m [29.5 ft.]
MINIMUM PLATFORM HEIGHT	1.5 m [59 in.]	1.5 m [59 in.]
MAXIMUM DRIVE HEIGHT	7.90 m [26 ft.]	9.0 m [29.5 ft.]
DIMENSIONS		
WEIGHT	DIESEL: 3550 kg [7826 lbs.]	DIESEL: 3400 kg [7495 lbs.]
OVERALL WIDTH, STANDARD	2.13 m [84 in.]	2.13 m [84 in.]
OVERALL HEIGHT	2.6 m [102.5 in.]	2.6 m [102.5 in.]
OVERALL LENGTH, STANDARD	3.79 m [149 in.]	4.39 m [173 in.]
SURFACE SPEED		
PLATFORM LOWERED HIGH/LOW	0 TO 5.0 km/h [0 TO 3.1 m.p.h.]	0 TO 5.0 km/h [0 TO 3.1 m.p.h.]
PLATFORM RAISED	0 TO 0.8 km/h [0 TO 0.5 m.p.h.]	0 TO 0.8 km/h [0 TO 0.5 m.p.h.]
SYSTEM VOLTAGE	12 VOLT DC	12 VOLT DC
HYDRAULIC TANK CAPACITY	74 L [19.5 US GALLONS]	47 L [19.5 US GALLONS]
MAXIMUM HYDRAULIC SYSTEM PRESSURE	210 bar [3000 psi]	210 bar [3000 psi]
HYDRAULIC FLUID		
ABOVE 32°F [0°C]	ISO #46 (SEE DECAL ON TANK)	ISO #46 (SEE DECAL ON TANK)
NORMAL USE, BELOW 32°F [0°C]	ISO #32	ISO #32
BELOW 0°F [-17°C]	ISO #15	ISO #15
LIFT SYSTEM	ONE SINGLE STAGE LIFT CYLINDER	ONE SINGLE STAGE LIFT CYLINDER
LIFT SPEED	RAISE: 21 SECONDS/LOWER: 32 SECONDS	RAISE: 24 SECONDS/LOWER: 36 SECONDS
PLATFORM LEVELLING	13° SIDE TO SIDE, 9° FRONT AND BACK	13° SIDE TO SIDE, 9° FRONT AND BACK
POWER SOURCE	20 HP (DIESEL), 15 kW	20 HP (DIESEL), 15kW
DRIVE CONTROL	PROPORTIONAL	PROPORTIONAL
CONTROL SYSTEM	JOYSTICK CONTROLLER WITH SAFETY	JOYSTICK CONTROLLER WITH SAFETY
	INTERLOCK TRIGGER AND THUMB ROCKER	INTERLOCK TRIGGER AND THUMB ROCKER
	STEERING, TOGGLE SELECTOR	STEERING, TOGGLE SELECTOR
	EMERGENCY STOP SWITCHES	EMERGENCY STOP SWITCHES
HORIZONTAL DRIVE	FOUR WHEEL, HYDRAULIC MOTORS	FOUR WHEEL, HYDRAULIC MOTORS
TYRES (STANDARD)	26 x 12.00 - 12 SUPER TERRA-GRIP WITH TRAC SEAL	26 x 12.00 - 12 SUPER TERRA - GRIP WITH TRAC SEAL
ANSI SPECIFICATION PNEUMATIC TYRE PRESSURE	DO NOT EXCEED 57 PSI	DO NOT EXCEED 57 PSI
PARKING BRAKES	DUAL SPRING APPLIED, HYDRAULIC RELEASE, MULTI DISC	DUAL SPRING APPLIED, HYDRAULIC RELEASE, MULTI DISC
TURNING RADIUS (INSIDE)	3.96 m [13 ft.]	3.96 m [13 ft.]
MAXIMUM GRADEABILITY	50% [27°]	50% [27°]
WHEEL BASE	2.54 m [100 in.]	2.54 [100 in.]
GUARDRAILS	1.7 m [67 in.] HIGH, FOLD DOWN WITH GATE	1.7 m [67 in.] HIGH, FOLD DOWN WITH GATE
TOEBOARD	152 mm [6 in.] HIGH	152 mm [6 in.] HIGH

SPECIFICATIONS

WHEEL LOADING	2000 kg (4400 lb)	2000 kg (4400 lb)
VIBRATION OF THIS MACHINE DOES NOT EXCEED	2.5 m/s ²	2.5 m/s ²
NOISE PRESSURE LEVEL	107 dB AT CONTROL STATION	107 dB AT CONTROL STATION
MACHINE VIBRATION	WHOLE BODY VIBRATION < 0.5 m/s ² , HAND ARM VIBRATION < 2.5 m/s ²	WHOLE BODY VIBRATION < 0.5 m/s ² , HAND ARM VIBRATION < 2.5 m/s ²

Table 2-3: SL26SL/SL30SL Specification

NOTE: Specifications are subject to change without notice. Hot weather or heavy use may affect performance. Refer to the service manual for complete parts and service information. This machine meets or exceeds all applicable OSHA and ANSI A92.6 - 1999.

WASTE DISPOSAL AND REMOVAL

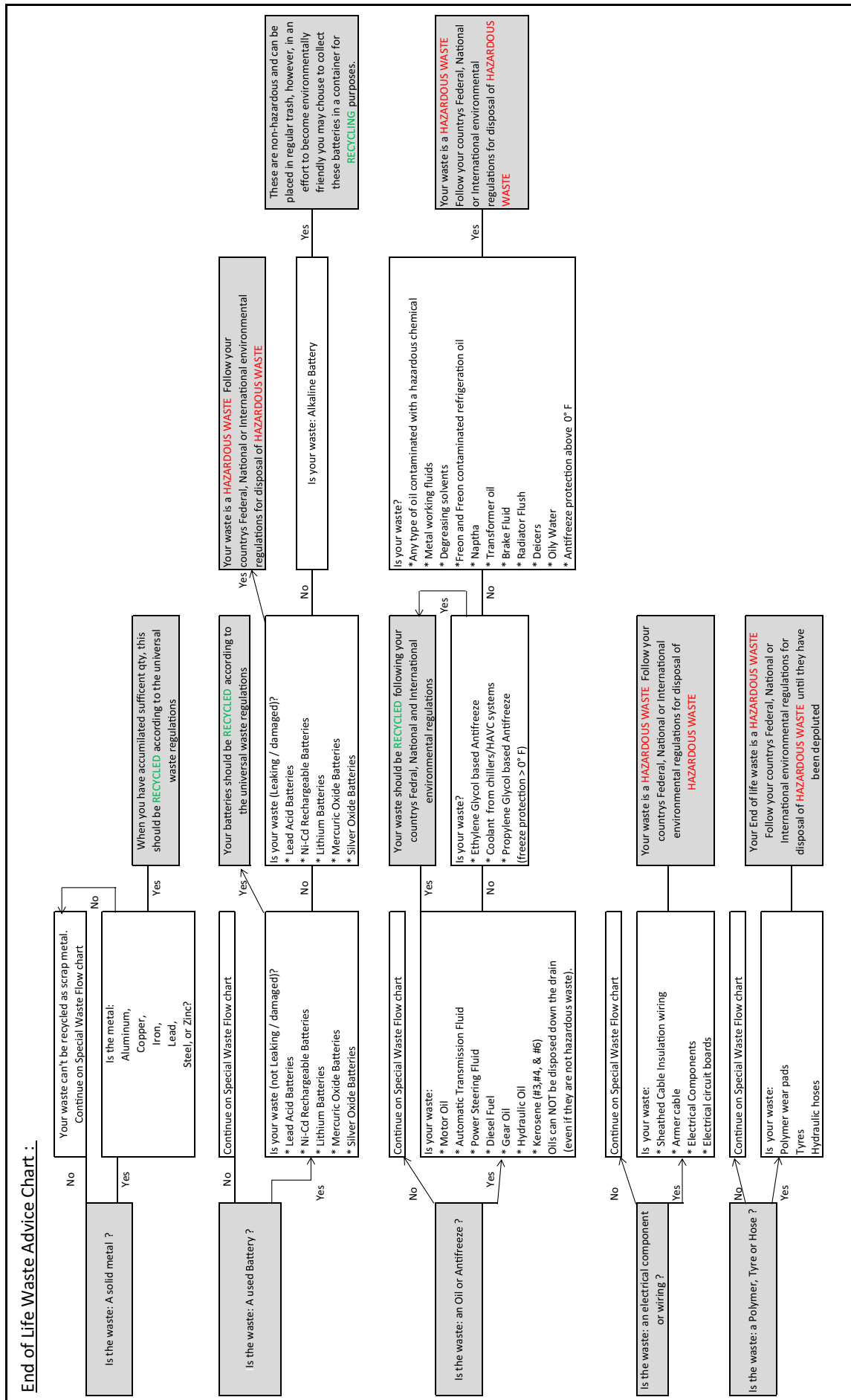

SERVICE AND REPAIR

CONTENTS			
INTRODUCTION	3-2	STEERING CYLINDER	3-12
SPECIAL TOOLS	3-2	REMOVAL	3-12
PREVENTATIVE MAINTENANCE	3-2	DISASSEMBLY	3-13
PREVENTATIVE MAINTENANCE TABLE	3-3	CLEANING AND INSPECTION	3-13
CHOCKING THE ELECTRICAL ASSEMBLY	3-4	ASSEMBLY AND INSTALLATION	3-13
INSTALLATION	3-4	ADJUSTMENT	3-14
REMOVAL	3-4	LIFT CYLINDER	3-14
BATTERY MAINTENANCE	3-4	INSTALLATION	3-14
BATTERY INSPECTION AND CLEANING	3-4	REMOVAL	3-14
BATTERY CHARGING	3-5	DISASSEMBLY	3-15
BATTERY SPECIFIC GRAVITY	3-5	CLEANING AND INSPECTION	3-15
LUBRICATION	3-5	REASSEMBLY	3-15
GREASE FITTINGS	3-5	INSTALLATION	3-15
LINKAGE GEARS	3-5	MANUAL LEVELLING	3-16
STEERING LINKAGE	3-5	PLATFORM CONTROLS AND INDICATORS	3-16
HYDRAULICS	3-6	CALIBRATE LEVEL	3-17
HYDRAULIC PUMP	3-6	CALIBRATE HEIGHT	3-19
HYDRAULIC OIL TANK AND FILTER	3-6	CALIBRATE LOAD	3-20
OIL FILTER AND REPLACEMENT	3-6	TORQUE SPECIFICATIONS	3-22
SETTING HYDRAULIC PRESSURES	3-6	FASTENERS	3-22
MAIN RELIEF VALVE RV3	3-7		
LIFT RELIEF VALVE RV2	3-7		
FORE/AFT TILT STEERING RELIEF VALVE RV1	3-7		
COUNTERBALANCE VALVES	3-7		
HYDRAULIC MANIFOLD	3-9		
REMOVAL	3-9		
DISASSEMBLY	3-9		
CLEANING AND INSPECTION	3-9		
ASSEMBLY	3-9		
INSTALLATION	3-9		
REPLACING HYDRAULIC PUMP	3-10		
REMOVAL	3-10		
INSTALLATION	3-10		
HYDRAULIC BRAKES, DRIVE MOTORS & HUBS	3-10		
REAR AXLE REMOVAL	3-10		
REAR AXLE INSTALLATION	3-11		
FRONT AXLE REMOVAL	3-11		
FRONT AXLE INSTALLATION	3-12		
AXLE CYLINDER	3-12		
REMOVAL	3-12		
INSTALLATION	3-12		

SERVICE AND REPAIR

INTRODUCTION

! WARNING !

Be sure to read, understand and follow all information in the operation section of this manual before attempting to operate or perform service on any SL26/30SL work platform.

! CAUTION !

It is the responsibility of the person carrying out any maintenance operations to ensure that any hazardous substances eg waste oil, batteries or tyres are disposed of in accordance with local regulations.

! CAUTION !

Detailed descriptions of standard workshop procedures, safety principles and service operations are not included. Please note that this manual contains warnings and cautions against some specific service methods which could cause personal injury or could damage a machine or could make it unsafe. Please understand that these warnings cannot cover all conceivable ways in which service, whether or not recommended by Snorkel, might be carried out or of the possible hazardous consequences of each conceivable way nor could Snorkel investigate all such ways. Anyone using service procedures or tools whether or not recommended by Snorkel, must satisfy themselves thoroughly that neither personal safety nor machine safety will be jeopardized

This section contains instructions for the maintenance of the SL26/30SL work platform. Procedures for operation inspection, adjustment, scheduled maintenance and repair/removal are included.

Referring to section 2 will aid in understanding the operation and function of the various components and systems of the SL26/30SL work platform and help in diagnosing and repair of the machine.

Refer to page 3-2 for recommended maintenance intervals.

NOTE: Unless otherwise specified, torque all fittings according to the “Torque Specifications for Fasteners” and the “Torque Specifications for Hydraulic Components” on page 3-22 and page 3-23.

SPECIAL TOOLS

The following is a list of special tools which may be required to perform certain maintenance procedures on the work platform.

- 0-600 PSI (0-45 bar) hydraulic pressure gauge
- 0-3500 PSI (0-250) hydraulic pressure gauge
- Inclinator
- Quick disconnect gauge port

PREVENTATIVE MAINTENANCE

The complete inspection consists of periodic visual and operational checks together with all necessary minor adjustments to assure proper performance. Daily inspection will prevent abnormal wear and prolong the life of all systems. The inspection and maintenance schedule is to be performed at regular intervals.

Inspection and maintenance shall **ONLY** be performed by personnel who are trained and familiar with mechanical and electrical procedures.

! WARNING !

Before performing maintenance, familiarize yourself with the operation of the machine. Always chock the elevating assembly whenever it is necessary to enter elevating assembly

The preventative maintenance table has been designed to be used primarily for machine service and maintenance repair.

Please photocopy the preventative maintenance checklist on page 3-3 and use this table as a checklist when inspecting the machine for service.

PREVENTATIVE MAINTENANCE TABLE

INTERVAL

Daily = each shift or everyday
 50 hrs/30 d = every 50 hours or 30 days
 250 hrs/6 m = every 250 hours or 6 months
 1000 hrs/2 y = every 1000 hours or 2 years
 Y = Yes/Acceptable
 N = No/Not Acceptable
 R = Repaired/Acceptable

PREVENTATIVE MAINTENANCE REPORT

Date:
 Owner:
 Model #:
 Serial #:
 Serviced By:
 Service Interval:

DO NOT fit replacement parts other than genuine components without express written approval from the manufacturer.

COMPONENT	INSPECTION OR SERVICES	INTERVAL	Y	N	R
Battery System	Check electrolyte level	Daily			
	Check specific gravity	6m			
	Clean exterior	6m			
	Check battery cable condition	Daily			
	Clean terminals	6m			
Engine Oil	Check level and condition	Daily			
	Check for leaks	Daily			
	Change oil filter	30d			
Engine Fuel system	Check fuel level	Daily			
	Check for leaks	Daily			
	Replace fuel filter	6m			
	Check air cleaner	Daily			
Engine Coolant	Check coolant level (with engine cold)	Daily			
	Replace coolant	3m			
Hydraulic Oil	Check oil level	Daily			
	Change filter	6m			
	Drain and replace oil	2y			
Hydraulic system	Check for leaks	Daily			
	Check hose connections	30d			
	Check hoses for exterior wear	30d			
Emergency hydraulic System	Operate the emergency lowering valve and check for serviceability	Daily			
Controller	Check switch operation	Daily			
Control Cable	Check the exterior of the cable for pinching, binding or wear	Daily			
Platform deck and rails	Check fasteners for proper torque	Daily			
	Check welds for cracks	Daily			
	Check condition of deck	Daily			
Tyres	Check for damage	Daily			
	Check lug nuts (torque to 122 Nm/90 ft. lbs.)	30d			
Hydraulic pump	Wipe clean	30d			
	Check for leaks at mating surfaces	30d			
	Check for hose fitting leaks	Daily			
	Check mounting bolts for proper torque	30d			
Entire unit	Check for and repair collision damage	Daily			
	Check fasteners for proper torque	3m			
	Check for corrosion-remove and paint	6m			
	Lubricate	30d			

COMPONENT	INSPECTION OR SERVICES	INTERVAL	Y	N	R
Drive Motors	Check for operation and leaks	Daily			
Steering system	Check hardware & fittings for proper torque	6m			
	Grease pivot pins	30d			
	Oil king pins	30d			
	Check steering cylinder for leaks	30d			
Elevating Assembly	Inspect for structural cracks	Daily			
	Check pivot points for wear	30d			
	Check mounting pin pivot bolts for proper torque	30d			
	Check linkage gear for wear	6m			
	Check elevating arms for bending	6m			
	Grease linkage pins	30d			
	Grease linkage gear	30d			
Chassis	Check hoses for pinch or rubbing points	Daily			
	Check component mounting for proper torque	6m			
	Check welds for cracks	Daily			
Lift Cylinder	Check the cylinder rod for wear	30d			
	Check mounting pin pivot bolts for proper torque	30d			
	Check seals for leaks	30d			
	Inspect pivot points for wear	30d			
	Check fittings for proper torque	30d			
Fore/Aft cylinder & side/side cylinder	Check the cylinder rod for wear	30d			
	Check mounting pin pivot bolts for proper torque	30d			
	Check seals for leaks	30d			
	Inspect pivot points for wear	30d			
	Check fittings for proper torque	30d			
Axle cylinder	Check the cylinder rod for wear	30d			
	Check mounting pin pivot bolts for proper torque	30d			
	Check seals for leaks	30d			
	Inspect pivot points for wear	30d			
	Check fittings for proper torque	30d			
Labels	Check for peeling, missing or unreadable labels & replace	Daily			
Wheel bearings	Replace wheel bearings (replace wheel bearings and seals at 2000 hours)	2y			

Table 3-1: Preventative maintenance checklist

A thorough investigation should be carried out every 6 months.

NOTE: Frequency and extent of periodic examinations may depend on national regulations.

Fitment of any component other than approved items designed for use with this machine can result in serious danger to operators, property and bystanders.

SERVICE AND REPAIR

CHOCKING THE ELEVATING ASSEMBLY

CAUTION

DO NOT support or raise the front of the platform during any maintenance operation as this may result in damage to the tension members.

WARNING

Before performing maintenance on a work platform while it is elevated, ensure that the elevating assembly is properly supported.

DO NOT stand under the elevated assembly area while installing or removing the jackstand.

INSTALLATION

1. Park the work platform on a firm, level ground and leave the engine running.
2. Elevate the platform approximately 300 mm (12 inches).
3. Place a jackstand with a minimum rating of 2000 kg (400 lbs.) between the lower mast and chassis, just behind the front axle.
4. Gradually lower the platform until the jackstand is secured tightly between the lower mast and chassis.

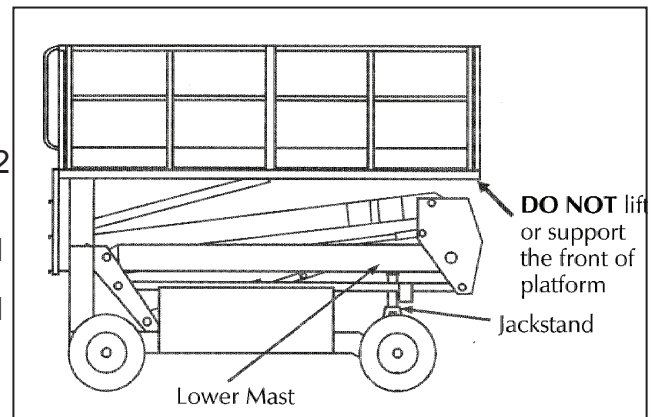

Figure 3-1: Blocking the elevating assembly

REMOVAL

Elevate the platform until the jackstand can be removed. Remove the jackstand and completely lower the platform.

BATTERY MAINTENANCE

WARNING

Hazard of explosive gas mixture. Keep sparks, flame and smoking material away from batteries.

Always wear safety glasses when working with batteries.

Battery fluid is highly corrosive. Thoroughly rinse away any spilled fluid with clean water.

BATTERY INSPECTION AND CLEANING

Check the battery fluid level daily, especially if the work platform is being used in a warm, dry climate. If required, add distilled water only. Use of tap water will shorten battery life due to its high mineral content. The battery and cables should be inspected regularly for signs of cracks in the case, electrolyte leakage and corrosion of the terminals. Inspect cables for worn spots or breaks in the insulation and for broken cable terminals. Clean the battery when it shows signs of corrosion at the terminals or when the electrolyte has overflowed during charging. Use a suitable solution to clean the battery, taking care not to get the solution inside the cells. Rinse thoroughly with clean water. Clean battery and cable contact surfaces to a bright metal finish whenever a cable is removed.

BATTERY CHARGING

The battery is charged by the alternator whenever the engine is running and should not require any other charging. If the machine has not been in service or the battery has been discharged, perform the following.

1. Charge the battery, only in a well ventilated area.
2. Do not charge the battery when the work platform is in an area containing sparks or flames.
3. Always follow the manufacturer's instructions.
4. Never disconnect the cables from the batteries when the charger is operating.

Check the battery fluid level. If the electrolyte level is lower than 10 mm (0.375 inches) above the plates, add clean distilled water only.

BATTERY SPECIFIC GRAVITY

After charging, if necessary, the specific gravity of all cells should be checked with a hydrometer. The temperature corrected specific gravity should be 1.260. If the battery contains any cells with corrected reading below 1.230, the battery should be replaced.

Do not check the specific gravity in a cell to which water has just been added. If there is not enough electrolyte in a fully charged cell to obtain a sample for the hydrometer, add water and continue charging for 1 to 2 hours to adequately mix the water and electrolyte.

LUBRICATION

Refer to Table 3-1 for lubrication intervals and Figure 3-2 for location of items that require lubrication service. Refer to the appropriate sections for lubrication information on the hydraulic tank and filter.

GREASE FITTINGS

Wipe each grease fitting before and after greasing. Using a lithium based multipurpose grease in a grease gun, pump the grease into the fitting until grease begins to appear at the edges of the pivot. Wipe off any excess grease.

LINKAGE GEARS

1. Raise platform fully.
2. Using another work platform or ladder, get up high enough to comfortably reach the gears.
3. Use a long handled brush to apply gear linkage lubricant (part number): 509594-000.
4. Lower the platform after greasing.

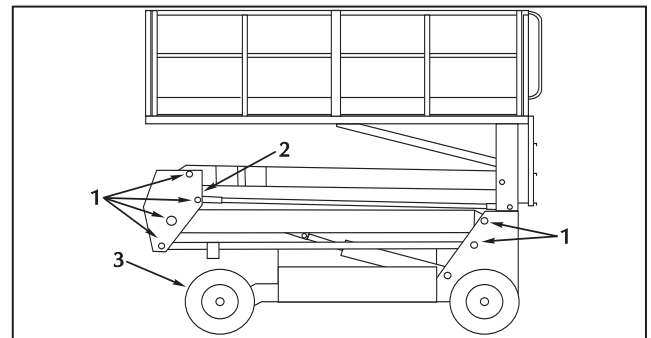

Figure 3-2: Lubrication points

1	Grease fittings	3	Steering linkage
2	Linkage gears		



STEERING LINKAGE

Apply one or two drops of SAE 10 W or spray lube oil to each pivot and grease upper and lower king pin bearing.

SERVICE AND REPAIR

HYDRAULICS

HYDRAULIC PUMP

Remove the cap screws that mount the pump to the engine. Remove the pump from the engine and apply high pressure molybdenum grease to the splines. Re-install the pump and secure the cap screws. Tighten using a torque of 30 Nm.

HYDRAULIC OIL TANK & FILTER

Fluid Level:

- With the platform fully lowered, the oil should be between the levels 'low and high'.
- If the oil is not visible, fill the tank until the oil can be seen.
- Do not fill the oil tank above the high level mark or when the platform is elevated.

OIL AND FILTER REPLACEMENT

1. Operate the work platform for 5 minutes to warm up the oil. To change filter only, refer to step 5.



2. Use a suitable container to drain the oil into. The hydraulic tank has an oil capacity of 75 litres.
3. Remove the drain plug and allow all the oil to drain into the container. Make sure the oil is disposed off properly.
4. Re-install the drain plug.
5. Unscrew the filter element from the filter body.
6. Lubricate the rubber seal and fill the tank with clean hydraulic oil.
7. Screw the replacement filter element onto the filter body.
8. Fill the hydraulic oil tank to the level required with the recommended fluid. Check decals for details on oil to use. The standard oil to use is ISO #46. The oil is being strained as it enters the tank leading to an increase in the time used to fill the tank.

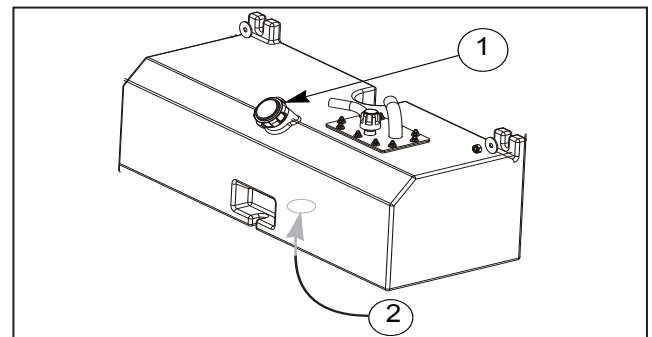
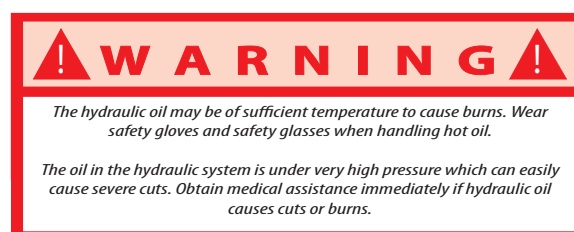

Figure 3-3: Hydraulic oil tank

1	Filler breather	2	Drain Plug (under tank)
---	-----------------	---	-------------------------

SETTING HYDRAULIC PRESSURES

NOTE: Check the hydraulic pressures whenever the pump, manifold or relief valve(s) have been serviced or replaced.



MAIN RELIEF VALVE RV3

Refer to Figure 3-4 while reading the following procedures.

1. Operate the hydraulic system 10 to 15 minutes to warm the oil.
2. Remove the cap or loosen the locknut on the main relief valve.
3. Install a 0-250 bar (0-3500 psi) pressure gauge to the gauge port.
4. Select "Drive mode" and remove the wires from the forward/reverse drive coils.
5. While engaging the safety interlock trigger, move the joystick fully forward. Adjust the main relief valve until the pressure gauge reads 210 bar (3000 psi).
6. Release the joystick.
7. Replace the cap or tighten the locknut on the main relief valve and torque to 8 Nm (6 ft. lbs.)

LIFT RELIEF VALVE RV2

Refer to Figure 3-4 while reading the following procedures.

1. Operate the hydraulic system for 5 minutes.
2. Remove the cap or loosen the locknut on the lift relief valve.
3. Install a 0-250 bar (0-3500 psi) pressure gauge.
4. With the engine running, select "lift mode". Lift the platform fully by moving the joystick fully forward.
5. While holding the joystick forward, set the pressure to 180 bar (2600 psi) maximum by slowly turning the adjustment screw. A clockwise turn increases pressure.
6. Tighten the locknut to 8 Nm (6 ft. lbs.).
7. Remove the gauge.

FORE/AFT TILT AND STEERING RELIEF VALVE RV1

Refer to Figure 3-4 while reading the following procedures.

1. Operate the hydraulic system for 5 minutes.
2. Remove the cap or loosen the locknut on the main relief valve.
3. Install a 0-100 bar (0-1450 psi) pressure gauge.
4. With the engine running, steer the wheels fully left or right using the steering buttons.
5. While holding the steering button, set the pressure to 100 bar (1450 psi) maximum by slowly turning the adjusting screw. A clockwise turn increases pressure.
6. Tighten locknut to 8 Nm (6 ft. lbs.).
7. Remove the gauge.

COUNTERBALANCE VALVES

The counterbalance valves are not adjustable. If a suspected problem exists, a counterbalance valve can be changed for one of the same specification.

Movement Manifold

PORTING:

PORTS 'T1' 'T2' 'P1' 'P3' - G3/4" BSPP
 PORTS 'LP' - G1/2" BSPP
 PORT 'P2' 'LR' - G3/8" BSPP
 ALL OTHER PORTS - G1/4" BSPP

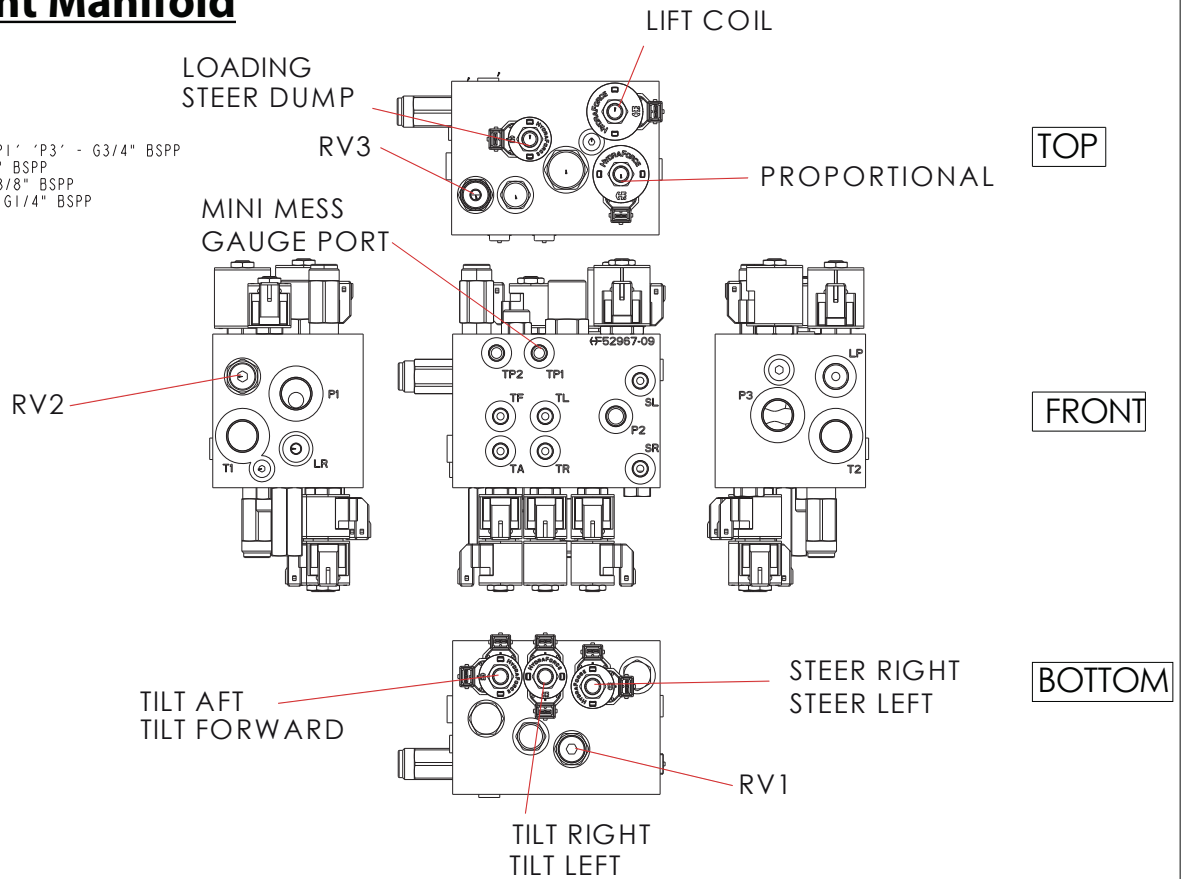

Drive Manifold

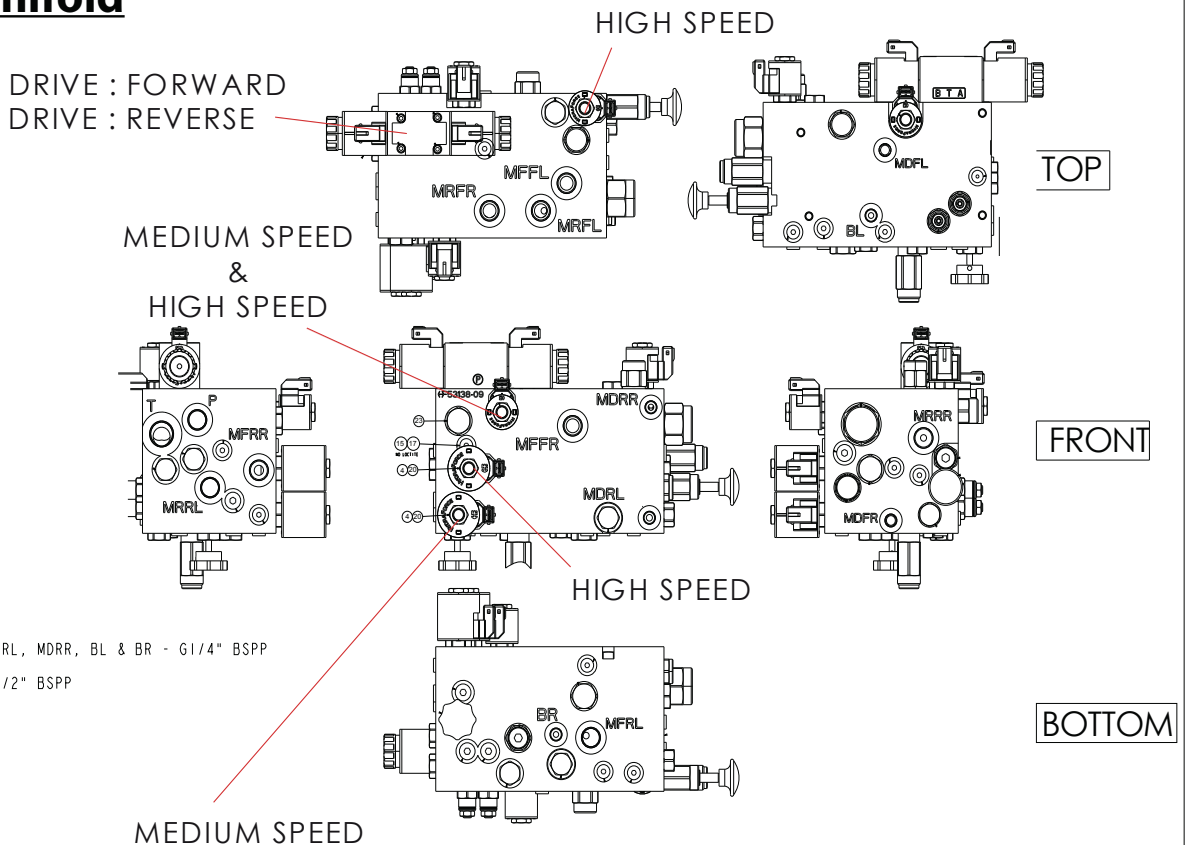

Figure 3-4: Hydraulic manifold (coil and port)

HYDRAULIC MANIFOLD

Though it is not always necessary to remove the manifold to perform maintenance procedures, a decision should be made prior to beginning as to whether or not the manifold should be removed before maintenance procedures begin. This work should only be carried out by competent and approved technicians in a clean environment.

REMOVAL

1. Disconnect the battery earth cable.
2. Tag and disconnect the solenoid valve leads.
3. Tag, disconnect and plug the hydraulic hoses.
4. Remove the bolts that hold the manifold to the mounting bracket.
5. Remove manifold block.

DISASSEMBLY

NOTE: Mark all components as they are removed to avoid confusion of their location during assembly. Refer to the valve block drawing and schematic regularly to aid in disassembly and assembly.

1. Remove coils from solenoid valves.
2. Remove spool valve covers and spool valves.
3. Remove solenoid valves, main relief valve, counterbalance valves and emergency lowering valves. Remove fittings, plugs, springs, balls and orifices.

CLEANING AND INSPECTION

1. Wash the manifold in cleaning solvent to remove built up contaminants and then blow out all passages with clean compressed air.
2. Inspect the manifold for cracks, thread damage and scouring where the O-rings seal acts against internal and external surfaces.
3. Wash and dry each component and check for thread damage, torn or cracked O-rings and proper operation.
4. Replace parts and O-rings found unserviceable.

ASSEMBLY

NOTE: Lubricate all O-rings before installation to prevent damage to O-rings. Seat all balls in manifold block by lightly tapping on the ball with a brass drift.

1. Install fittings, plugs, balls and orifices. Use one drop of loctite #242 on each screw-in orifice.
2. Install emergency lowering valves, counterbalance valves, main relief valve, break pressure reducing valve, solenoid valves and spool valves.
3. Install coils on solenoid valves.

INSTALLATION

1. Attach manifold assembly to mounting plates with bolts.
2. Connect solenoid leads (as previously tagged).
3. Connect hydraulic hoses. Be certain to tighten hoses to manifold.
4. Operate each hydraulic function and check for proper operation and leaks.
5. Adjust all hydraulic pressures according to instructions.

SERVICE AND REPAIR

REPLACING HYDRAULIC PUMP

NOTE: If the hydraulic tank has not been drained, suitable means for plugging the hoses should be provided to prevent excessive fluid loss.

REMOVAL

1. Mark, disconnect and plug the hose assemblies.
2. Loosen the cap screws and remove the pump assemblies from the engine.

INSTALLATION

1. Lubricate the pump shaft with extreme high pressure molybdenum grease and attach the pump to the engine with cap screws.
2. Using a crisscross pattern, torque each cap screw a little at a time until all four cap screws are torqued to 30 Nm (22 ft. lbs.).
3. Unplug and re-connect the hydraulic hoses.
4. Check the oil level in the hydraulic tank before operating the work platform.

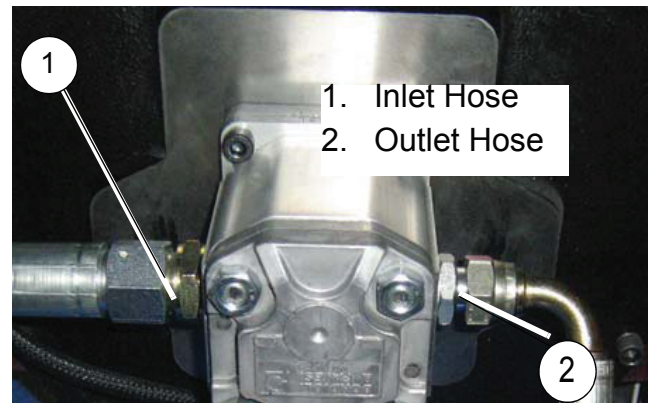
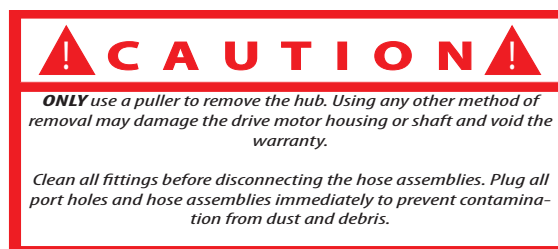

Figure 3-5: Typical hydraulic pump

HYDRAULIC BRAKES, DRIVE MOTORS & HUBS

REAR AXLE REMOVAL

1. Park the work platform on firm, level ground and block the wheels to prevent the work platform from moving.
2. Loosen the wheel lug bolts on the motor to be removed.
3. Raise the rear of the work platform using a 2 tonne jack.
4. Position two 1 tonne jack stands under the rear axle to prevent the work platform from falling if the jack fails.
5. Remove the wheel lug bolts and wheel.
6. Remove the cotter pin, nut, hub and shaft key.



7. Tag and disconnect the hose assemblies.
8. Remove the cap screws, washers, brake and drive motor assembly from the rear axle.
9. Remove the socket screws from the drive motor and then separate the brake from the drive motor.

REAR AXLE INSTALLATION

1. Insert the drive motor with O-ring (lubricate O-ring before assembly) installed unto the brake and secure the socket screws using loctite #242 retaining compound on the screw threads.
2. Position the drive motor and brake on the rear axle and secure with washers and H.H. set-screws.
3. Re-install the hose assemblies.
4. Re-install the shaft key, hub and nut. Torque each wheel hub nut to 475 Nm (350 ft. lbs.).
5. Align the slot in the nut with the hole in the shaft and insert the cotter pin. Do not back off the nut to align.
6. Re-install the wheel and lug on the hub. Torque the bolts to 123 Nm (90 ft. lbs.).
7. Lower the jack stands and remove.
8. Operate the drive system to check for leaks and proper function.

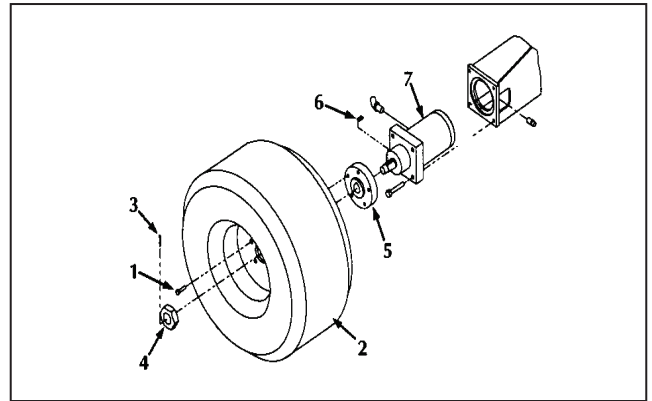

Figure 3-6: Rear axle assembly

1	Lug bolt	2	Tyre/Wheel Assembly
3	Cotter pin	4	Slotted nut
5	Adaptor hub	6	Shaft key
7	Drive motor		

FRONT AXLE REMOVAL

1. Park the work platform on firm, level ground and chock the wheels to prevent the work platform from moving.
2. Loosen the wheel lug bolts on the motor to be removed.
3. Raise the front of the chassis using a 2 tonne jack.
4. Position two 1 tonne jack stands under the front axle to prevent the work platform from falling if the jack fails.
5. Remove the wheel lug bolts and wheel.
6. Remove the cotter pin, nut, hub and shaft key.
7. Tag and disconnect the hose assemblies.
8. Remove the adaptor hub from the hydraulic motor.
9. Remove the cap screws and nuts followed by the drive motor from the front axle steering mount.

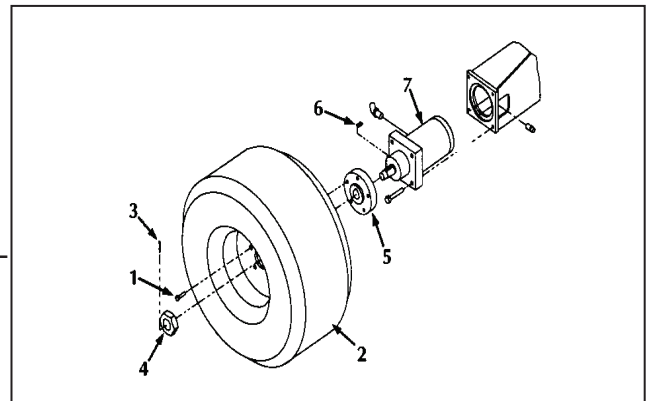
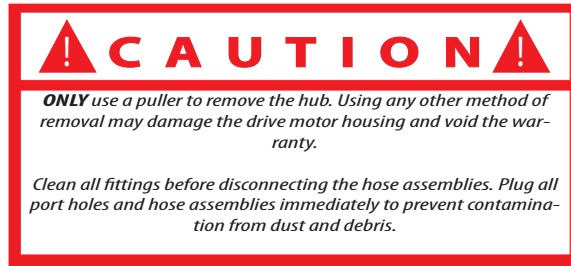

Figure 3-7: Front axle assembly

1	Lug bolt	2	Tyre/Wheel Assembly
3	Cotter pin	4	Slotted nut
5	Adaptor hub	6	Shaft key
7	Drive motor	8	Steering mount



FRONT AXLE INSTALLATION

1. Position the drive motor into the steering mount and secure the cap screws and nuts.
2. Re-install the adaptor on the hydraulic motor.
3. Re-install the hose assemblies.
4. Re-install the shaft key, hub and nut. Torque each wheel hub nut to 475 Nm (350 ft. lbs.). Align the slot in the nut with the hole in the shaft and insert the cotter pin. Do not back off the nut to align.
5. Re-install the wheel and lug bolts onto the hub. Torque the lug bolts to 123 Nm (90 ft. lbs.).
6. Lower the jack stands and remove.
7. Operate the drive system to check for leaks and proper function.

AXLE CYLINDER

REMOVAL

Ensure the platform is fully lowered and the machine is on a firm level ground.

1. Remove and cap the hoses.
2. Remove the pivot pins.
3. Remove the cylinder.

INSTALLATION

1. Attach both ends of the cylinder to mounts with pivot pins and retaining bolts.
2. Torque the retaining bolts to 203 Nm (150 ft. lbs.).
3. Connect all hoses.
4. Jack up the front axle and support.
5. With the engine running, oscillate the axle from side to side slowly to bleed air from the cylinder and hoses.
6. Lower the axle to the ground.
7. Operate the work platform over rough terrain and check for proper function and leaks. This is done by elevating the platform above 2 m (levelling may be required). Drive the platform so that one wheel drives up an incline of 150 mm (6 inches). The platform should continue to drive until the wheel diagonally opposite lifts off the ground and the tilt sensor is activated. If this cannot be achieved, either the float cylinder contains air or the float cylinder solenoid valve is faulty.

STEERING CYLINDER

REMOVAL

1. Mark and disconnect the hose assemblies from the fittings and immediately cap the openings to prevent foreign material from entering.
2. Remove the setscrews securing the rod ends to the steering linkage.
3. Remove the setscrews and locknuts that fasten the cylinder assembly to the chassis.
4. Remove the cylinder from the chassis.

DISASSEMBLY

1. Remove the head caps from the barrel tube.
2. Mark which end of the barrel tube the head cap was removed from.
3. Withdraw the entire shaft assembly from either end of the barrel tube.
4. Remove the rod wipers, rod seals and static O-rings from the head caps.
5. Discard all the seals.
6. Unscrew the #1 shaft from the #2 shaft and remove the piston.
7. Remove the piston seal and static O-ring from the piston and discard.

CLEANING AND INSPECTION

1. Wash all the metal parts in cleaning solvent and blow dry with filtered compressed air.
2. Inspect all the threaded components for stripped or damaged threads.
3. Check the inside surface of the barrel tube for scouring or excessive wear.
4. Check the piston and head caps for scouring or excessive wear.
5. Inspect the surface of both shafts for scouring or excessive wear.

ASSEMBLY AND INSTALLATION

1. Install a new piston seal and static O-rings.
2. Install the piston on the #1 shaft.
3. Thread the #2 shaft onto the #1 shaft and tighten securely.
4. Lubricate the piston seal with clean hydraulic fluid and install the shaft assembly in the barrel tube.
5. Lubricate and install new rod seals and static O-rings on the head caps.
6. Lubricate and install new rod wipers on the head caps.
7. Install head caps on the barrel tube and tighten until the mounting holes are in line.

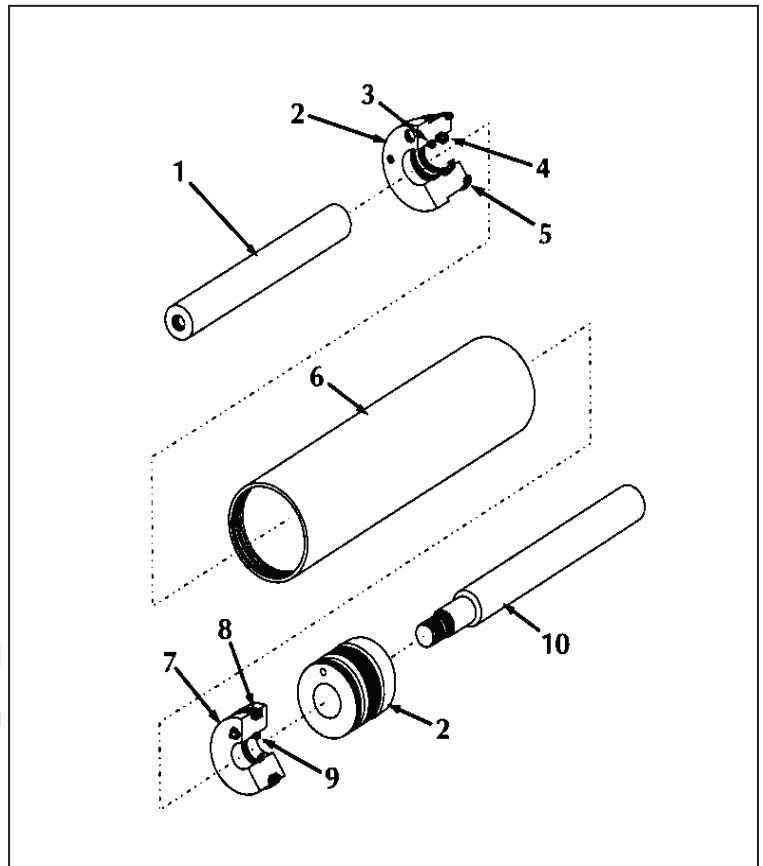

NOTE: Head caps must be re-installed on the same end from which they were removed.

Figure 3-8: Steering Cylinder assembly

1	#2 Shaft	2	Head cap (2)
3	Rod wiper (2)	4	Rod seal (2)
5	Static O-ring (2)	6	Cylinder barrel
7	Piston	8	Piston seal
9	Piston static O-ring		

8. Install the fittings on the ends of the cylinder.
9. Position the cylinder assembly on the chassis and install the cap screws and locknuts but do not tighten.
10. Tighten the nut and bolt in front of the cylinder that goes through the frame and then tighten the cylinder mounting cap screws.
11. Install the cylinder rod ends.
12. Set rod ends to align front wheels.
13. Connect the hose assemblies to the fittings.
14. Operate the steering circuit several times throughout its entire range of travel to expel trapped air and check for leaks.
15. Check and adjust front wheel tracking if required.

SERVICE AND REPAIR

ADJUSTMENT

1. Disconnect the cylinder rod ends (if connected).
2. Operate steering so that both ends of the cylinder rod are equal in length therefore within 0.8 mm (1/32 inch).
3. Position both tyres so that they are parallel with the frame, with each other and with the rear wheels.
4. Adjust rod ends until they align with the holes on the steering linkage bars.
5. Re-install the bolts through the steering linkage bars and rod ends. Tighten the jam nuts on the rod ends and all hardware.
6. When properly adjusted, the wheels must turn the same amount in each direction. The steering stops must make contact with each side at the same time.

LIFT CYLINDER

NOTE: Do not support or raise the front of the platform during any maintenance operation as this might result in damage to the tension members.

REMOVAL

1. Raise and chock the front of the elevating assembly approximately 300 mm (12 inches) above the chassis support with a jack stand; a minimum rating of 2000 kg (4000 lbs.).
2. Open the emergency lowering valve to ensure all the pressure is released from the lift cylinder.
3. Remove and cap both hoses and fittings.
4. Support the lift cylinder to prevent it from falling.
5. Remove the setscrew from the end of the cylinder rod.
6. Remove the retaining ring from the upper cylinder pin. Remove the upper cylinder pin by tapping out using a soft punch.
7. Remove the retaining bolt from the lower cylinder pin and remove the pin using a soft punch.
8. Remove the cylinder by sliding it out towards the front of the machine.

1	Cylinder barrel	2	Velocity fuse
3	Fitting, Adapter	4	Hose assembly
5	Breather	6	Piston nut
7	Piston seal	8	Piston
9	Piston static O-ring	10	Static O-rings
11	Head cap	12	Cylinder rod
13	Set screw	14	Rod wiper
15	Rod seal	16	Nut

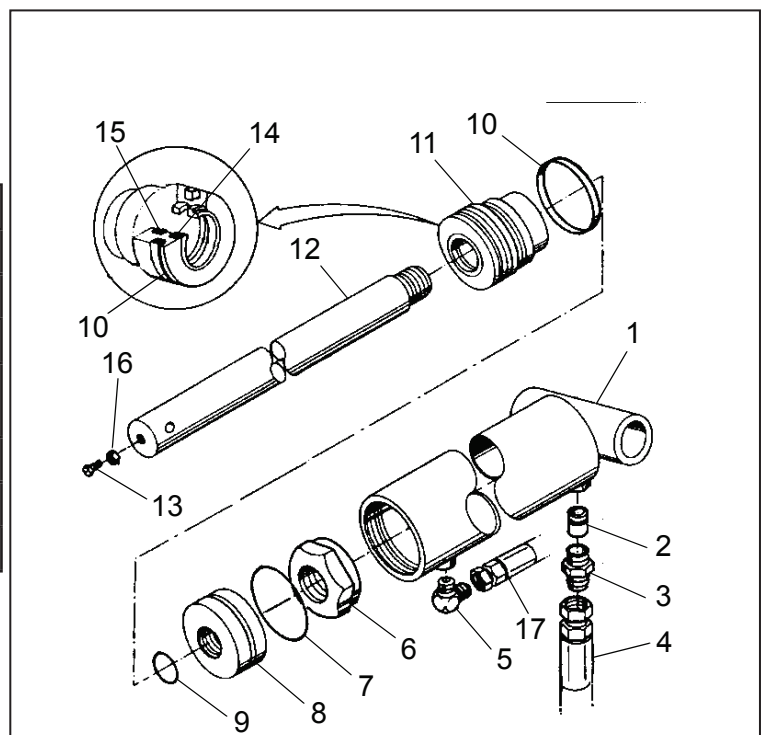

Figure 3-9: Steering Cylinder assembly

DISASSEMBLY

1. Unscrew the head cap from the cylinder barrel.
2. Remove the piston and rod assembly from the cylinder barrel.
3. Unscrew the piston nut and remove piston and head cap from the piston rod.
4. Remove the piston static O-ring from the cylinder rod and discard.
5. Remove the piston seal from the piston and discard.
6. Remove the static O-rings, rod seal and rod wiper.
7. Remove the rod end breather.
8. Do not remove the velocity fuse unless replacement is necessary.

CLEANING AND INSPECTION

1. Clean all the metal parts in cleaning solvent and blow dry with filtered compressed air.
2. Check the working surfaces of the piston head cap, cylinder barrel and rod for excessive wear or scouring.
3. Replace parts found to be unserviceable.
4. Replace all seals, O-rings and wipers.

RE-ASSEMBLY

1. Lubricate the static O-ring, rod seal and rod wiper and then install it on the head cap.
2. Install the piston seal on the piston.
3. Install the head cap, piston static seal, piston and piston nut on the cylinder rod. Torque nut to 96 Nm (70 ft. lbs.).

NOTE: The head cap should be installed from the piston end of the cylinder rod. Sliding the head cap over the pivot pin hole may damage the rod seal and rod wiper.

4. Lubricate the piston seal and install the piston and rod assembly into the cylinder barrel.
5. Screw the head cap into the cylinder barrel until it is tight. Turn a further 1/4 to ensure it is well tight.

INSTALLATION

NOTE: Before installing the cylinder, check the pins and bearings for excessive wear. Replace if necessary.

1. Place the cylinder in position taking care to support the cylinder to prevent falling.
2. Install the lower pin and retaining bolt.
3. Install the upper pin and retaining ring.
4. Install both hoses.
5. Raise the machine and check for leaks.

NOTE: The cylinder may need to be extended and retracted so as to align the rod end pivot hole.

MANUAL LEVELLING

- There are occasions when the operation of manual levelling is required.
 - Manual levelling cannot be carried out above the elevation height (approximately 2 m).
1. Select platform controls from the ground control box. Release the ground “Emergency stop button” and enter the platform (refer to Figure 2-4).
 2. Release the platform “Emergency stop button” (#1) and ensure the machine is switched OFF with the platform “OFF/ON Engine start switch”(#3).
 3. To access the manual levelling mode, press and hold the “Lift/Lower switch” (#12) and the “Auto level switch” (#14) and switch the machine on using the “OFF/ON Engine start switch” (#3). Release the toggle switches.
 4. When the manual levelling mode is active, the “Lift/Lower enabled LED” (#13) and the “Medium speed drive enabled LED” (#9) will flash.
 5. If the platform is out of level from right to left, the “High speed drive enabled LED” (#11) will flash. If the platform is out of level from front to back, the “Platform tilt-steady red axle tilt” (#15) will flash.
 6. Start the engine.
 7. For left to right adjustments, press and hold the “Auto level switch” (#14) then pull in the trigger on the joystick and use the steer switch on the joystick to adjust the platform level to left or right. The “High speed drive enabled LED” (#11) will extinguish when the platform is level in that direction.
 8. For Fore to Aft adjustment, press and hold the “Auto level switch” (#14) then pull in the trigger on the joystick and push the joystick forward or backwards to adjust the platform level Fore or Aft. The “Platform tilt-steady red axle tilt” (#15) will extinguish when the platform is level in that direction.
 9. To exit manual levelling mode, switch the machine off.

PLATFORM CONTROLS AND INDICATORS

1. Emergency stop button
2. Horn button
3. OFF/ON Engine start switch
4. Glow plug button
5. Engine warning LED
6. Low speed drive switch
7. Low speed drive enabled LED
8. Medium speed drive switch
9. Medium speed drive enabled LED
10. High speed drive switch
11. High speed drive enabled LED
12. Lift/Lower Switch
13. Lift/Lower enabled LED
14. Auto level switch
15. Platform tilt-steady red axle tilt - flashing red
16. Overload LED
17. Joystick

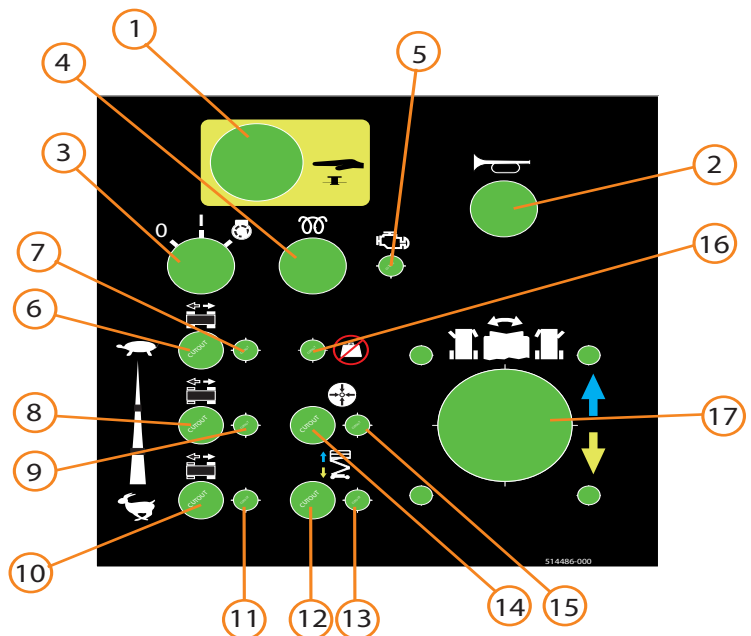
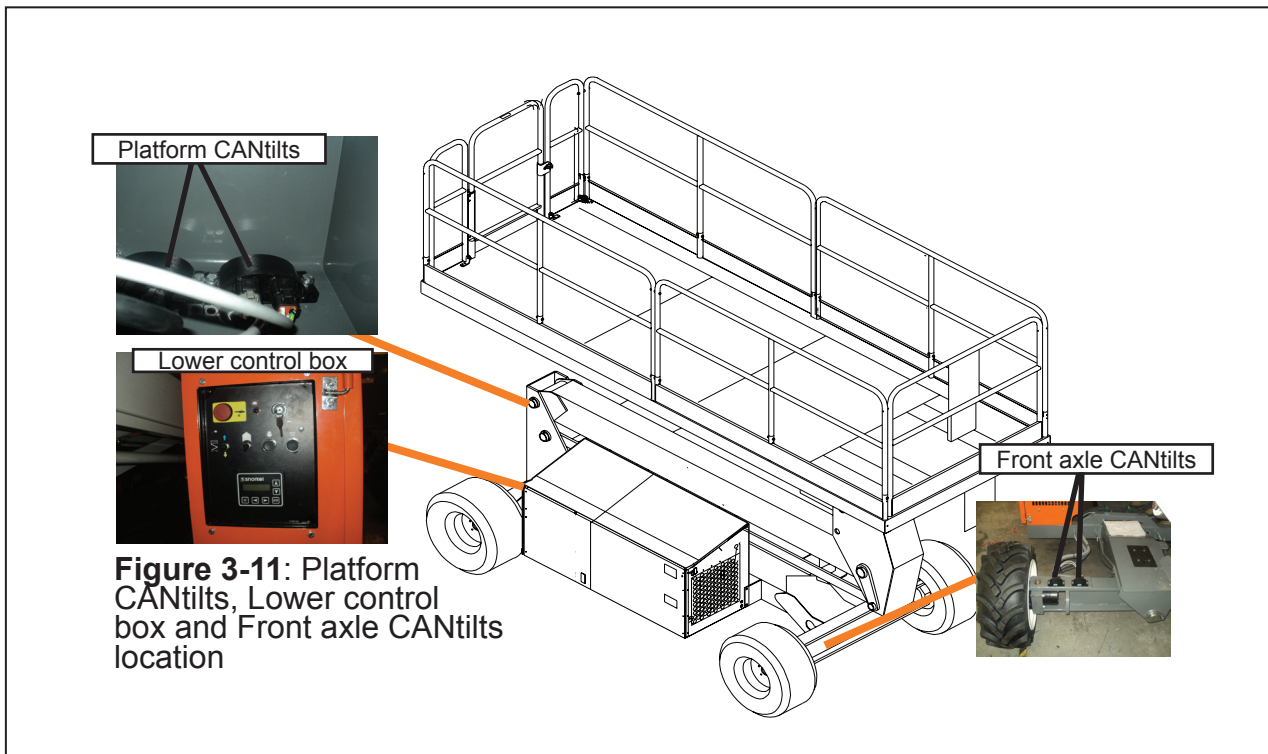

Figure 3-10: Platform Controls and indicator locations

CALIBRATE LEVEL

- This machine is equipped with level sensors for the chassis, the front axle and the platform as follows:
 1. Chassis level sensor: This is incorporated in the ECU (GP400 control module) in the lower control box.
 2. Front axle level sensor: This is a pair of CANtilt level sensors mounted on the front axle. There are two available for self checking incase one fails. Elevation above elevated height is not allowed if the front axle is out of level with the chassis by more than 1 degree.
 3. Platform level sensor: This is a pair of CANtilt level sensors mounted on the rear of the 1st post weldment. There are two available for self checking incase one fails.



! W A R N I N G !

If the GP400 control module or any of the CANtilt level sensors are replaced and/or moved, level on the full system must be recalibrated using the procedure provided. Failure to do so could result in serious injury or death.

SERVICE AND REPAIR

LEVELLING PROCEDURE

1. Place the machine on a firm, level surface. Using a digital inclinometer, check that the chassis and the front axle are level with each other within +/- 0.25 degrees side to side.
2. Using the manual levelling procedure (refer to page 3-15), level the platform using a digital inclinometer to within +/- 0.25 degrees.

NOTE: Since level has not yet been calibrated, ignore the level indicators on the platform and level using the digital inclinometer only.

3. Switch the machine to ground controls.
4. Press and hold "ESC" for 5 seconds until "#### MENU: HELP: PRESS ENTER" is displayed.
5. Scroll to "ACCESS LEVEL" and press "ENTER".
6. Enter the code 2222 for "ACCESS LEVEL 2" and press "ENTER".
7. Scroll to "SETUPS" and press "ENTER".
8. Scroll to "TILT SETUPS" and press "ENTER".
9. The question "CALIBRATE LEVEL" pops up. Press "ENTER".
10. Press "ENTER" for yes.

To confirm level calibration has worked, switch the machine off then back on again.

11. Press and hold "ESC" for 5 seconds.
12. Scroll to "DIAGNOSTICS" and press "ENTER".
13. Select "SYSTEM" and press "ENTER".
14. Scroll to "TILT" to display the platform tilt angles.
15. Press "ENTER" to display the chassis tilt angles.
16. Press "ESC" then scroll to "AXLE" and press "ENTER" to display the axle tilt angles.
17. All angles displayed during 14, 15 and 16 should be below 0.2 degrees. If not, repeat the procedure from 5.

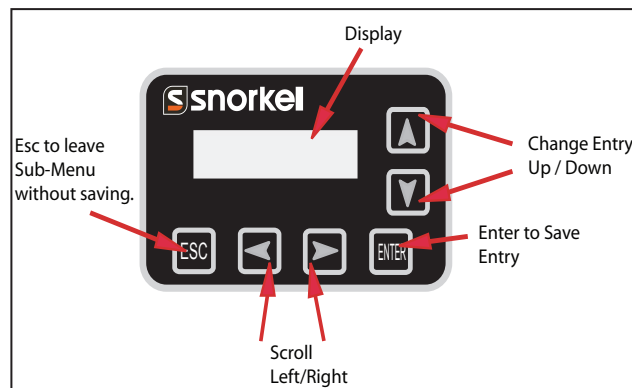

Figure 3-12: EZcal Display

CALIBRATE HEIGHT

- This machine has angle transducers (EZfit) attached to the boom which allows the ECU to calculate the platform height by comparing the boom angle with the platform angle. There are two available for self checking in case one fails.

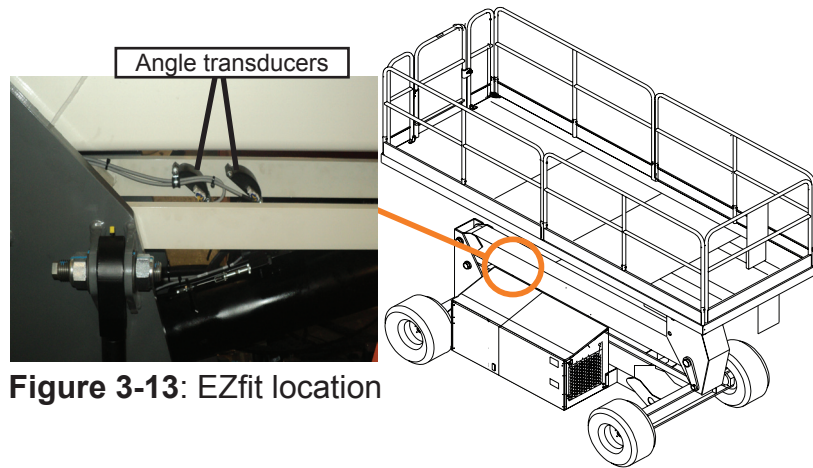

Figure 3-13: EZfit location

! WARNING !

If the GP400 control module, either of the boom angle transducers or either of the CANTilt level sensors are replaced and/or moved, platform height on the full system must be recalibrated using the procedure provided. Failure to do so could result in serious injury or death.

HEIGHT CALIBRATION PROCEDURE

If "LEVEL" hasn't been calibrated, then follow the procedure (refer to page 3-17) to "CALIBRATE LEVEL" first.

- Place the machine on a firm level surface and level the platform.
- Switch the machine to ground controls.
- Press and hold "ESC" for 5 seconds until "#### MENU: HELP: PRESS ENTER" is displayed.
- Scroll to "ACCESS LEVEL" and press "ENTER".
- Enter code 2222 for "ACCESS LEVEL 2" and press "ENTER".
- Scroll to "SETUPS" and press "ENTER".
- Scroll to "HEIGHT SETUPS" and press "ENTER".
- Scroll to "CALIBRATE HEIGHT" and press "ENTER".
- The question "PLATFORM DOWN" pops up. Check that the platform is fully lowered and press "ENTER".
- The suggestion "PLEASE LIFT" pops up. Use the lift controls to fully elevate the platform.
- The suggestion "PLEASE LOWER" pops up. Use the lower control to fully lower the platform.
- The suggestion "CAL DATE" pops up. Use the up and right arrows to enter the calibration date and press "ENTER".
- The suggestion "FINISHED" pops up. Height calibration is now finished.

SERVICE AND REPAIR

CALIBRATE LOAD

- This machine has a pressure transducer fitted to the lift cylinder which allows the ECU to calculate the platform load by comparing the lift pressure with load calibration curves stored in the ECU.

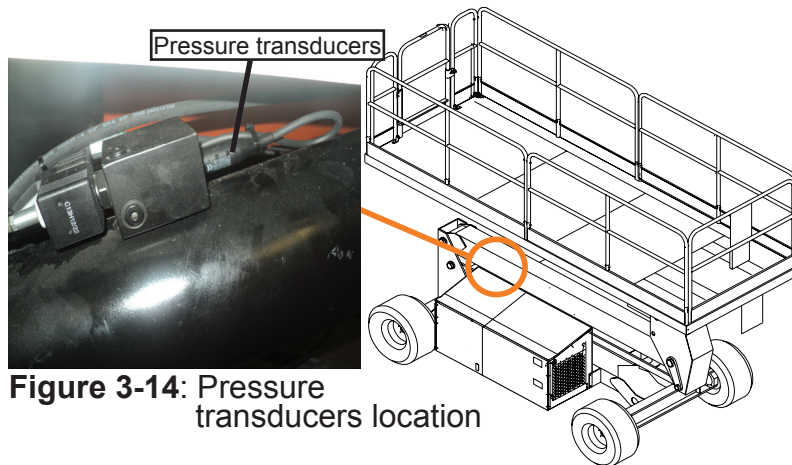

Figure 3-14: Pressure transducers location

! WARNING !

If the GP400 control module, either of the boom angle transducers or the lift cylinder pressure transducers are replaced and/or moved, platform load must be recalibrated using the procedure provided. Failure to do so could result in serious injury or death.

LOAD CALIBRATION PROCEDURE

If “LEVEL” hasn’t been calibrated, then follow the procedure (refer to page 3-17) to “CALIBRATE LEVEL” first.

If “HEIGHT” hasn’t been calibrated, then follow the procedure (refer to page 3-18) to “CALIBRATE HEIGHT” first.

- Place the machine on a firm level surface and level the platform.
- Switch the machine to ground controls.
- Press and hold “ESC” for 5 seconds until “##### MENU: HELP: PRESS ENTER” is displayed.
- Scroll to “ACCESS LEVEL” and press “ENTER”.
- Enter code 2222 for “ACCESS LEVEL 2” and press “ENTER”.
- Scroll to “SETUPS” and press “ENTER”.
- Scroll to “LOAD SETUPS” and press “ENTER”.
- Scroll to “CALIBRATE LOAD” and press “ENTER”.
- The question “REDO DYNAMIC” pops up. Press on the up arrow for yes and press “ENTER”.
- The question “PLATFORM DOWN” pops up. Press “ENTER” to confirm the platform is fully lowered.
- The question “PLATFORM LOADED” pops up. Place the safe working load (SWL) on the platform and press “ENTER”.
- The suggestion “PLEASE LIFT” pops up. Use the lift controls to fully elevate the platform. Do not release the control until the platform is fully elevated.
- The suggestion “PLEASE LOWER” pops up. Use the lower control to fully lower the platform. Do not release the control until the platform is fully lowered.
- The question “REDO LOADED” pops up. Press on the up arrow for yes and press “ENTER”.
- The question “PLATFORM LOADED” pops up. Place the safe working load (SWL) on the platform and press “ENTER”.
- The suggestion “PLEASE LIFT” pops up. Use the lift controls to fully elevate the platform. Do not release the control until the platform is fully elevated.

NOTE: During this elevation procedure, the platform will lift-stop-lift repeating the process several times taking load readings while the work platform is in a stationary position. Do not release the lift switch until the platform is fully elevated.

17. The suggestion "PLEASE LOWER" pops up. Use the lower control to fully lower the platform. Do not release the control until the platform is fully lowered.

NOTE: During this lowering procedure, the platform will lower-stop-lower repeating the process several times taking load readings while the work platform is in a stationary position. Do not release the lift switch until the platform is fully lowered.

18. The question "REDO EMPTY" pops up. Press on the up arrow for yes and press "ENTER".
19. The question "PLATFORM EMPTY" pops up. Remove the safe working load (SWL) from the platform and press "ENTER".
20. The suggestion "PLEASE LIFT" pops up. Use the lift controls to fully elevate the platform. Do not release the control until the platform is fully elevated.

NOTE: During this elevation procedure, the platform will lift-stop-lift repeating the process several times taking load readings while the work platform is in a stationary position. Do not release the lift switch until the platform is fully elevated.

21. The suggestion "PLEASE LOWER" pops up. Use the lower control to fully lower the platform. Do not release the control until the platform is fully lowered.

NOTE: During this lowering procedure, the platform will lower-stop-lower repeating the process several times taking load readings while the work platform is in a stationary position. Do not release the lift switch until the platform is fully lowered.

22. The suggestion "CAL DATE" pops up. Use the up and right arrows to enter the calibration date and press "ENTER".
23. The suggestion "FINISHED" pops up. Load calibration is now finished.

SERVICE AND REPAIR

TORQUE SPECIFICATIONS HYDRAULIC COMPONENTS

NOTE: Always lubricate threads with clean hydraulic oil prior to installation
Use the following values to torque hydraulic components used on Snorkel work platforms.

ORFS				JIC Hose fittings				BSP 60° cone	
Thread size	Tightening Nm	FFWR new	FFWR reassembly	Hose dim.	Thread	FFWR hose	FFWR pipe	Thread size	Tightening Nm
9/16" - 18	25	1/2-3/4	1/4-1/2	3/16	7/16"-20 UNF	2	2	1/8"	20
11/16" - 16	35	1/2-3/4	1/4-1/2		1/2"-20 UNF	2	2	1/4"	25
13/16 - 16	55	1/2-3/4	1/4-1/2	1/4	9/16"-18 UNF	2	1 1/2	3/8"	40
1" - 14	80	1/2-3/4	1/4-1/2	3/8	3/4"-16 UNF	2	1 1/2	1/2"	60
1 3/16" - 12	120	1/3-1/2	1/4-1/2	1/2	7/8"-14 UNF	1 1/2	1 1/2	5/8"	70
1 7/16" - 12	150	1/3-1/2	1/4-1/2	3/4	1.1/16"-12 UN	1	1 1/4	3/4"	115
1 11/16" - 12	180	1/3-1/2	1/4-1/2	1	1.5/16"-12 UN	1	1	1"	140
2" - 12	220	1/3-1/2	1/4-1/2	1 1/4	1.5/8"-12 UN	1	1	1 1/4"	200
2 1/2" - 12	490	1/3-1/2	1/4-1/2	1 1/2	1.7/8"-12 UN	1	1	1 1/2"	270
				2	2.1/2"-12 UN	1	1	2"	350

BSP Tread	Torque (Nm)	UN/UNF Thread	Torque (Nm)
G 1/8"			
G 1/8"	20	7/16"-20 UNF	20
G 1/4"	45	1/2"-20 UNF	25
G 3/8"	70	9/16"-18 UNF	30
G 1/2"	85	3/4"-16 UNF	45
G 1/2"	85		
G 3/4"	170	1 1/16"-12 UN	85
G 1"	330	1 5/16"-12 UN	130
G 1 1/4"	430	1 5/16"-12 UN	170
G 1 1/2"	510	1 7/8"-12 UN	180
		7/8"-14 UNF	55

Table 3-2: Hose fittings

Table 3-3: Hydraulic fittings

FASTENERS

This standard applies to the pre-loading of fasteners measured by installation torque.

NOTE: For other pre-loading methods or fasteners, consult Snorkel engineering department.

This general standard applies to all SAE and metric fasteners unless otherwise specified.

THREAD CONDITION

- For lube or zinc plated fasteners, use $k = 0.15$
- For dry unplated fasteners, use $k = .20$

	Nominal Thread Size	SAE J429 Grade 5			SAE J429 Grade 8		
		Clamp Load	Tightening Torque		Clamp Load	Tightening Torque	
			K=.15	K=.20		K=.15	K=.20
		lbs.	in-lbs.	in-lbs.	lbs.	in-lbs.	in-lbs.
Unified Coarse Thread Series	1/4 -20	2,000	75	100	2850	107	143
	5/16 - 18	3,350	157	210	4700	220	305
		lbs.	ft-lbs.	ft-lbs.	lbs.	ft-lbs.	ft-lbs.
	3/8-16	4,950	23	31	6950	32.5	44
	7/16-14	6,800	37	50	9600	53	70
	1/2-13	9,050	57	75	12800	80	107
	9/16-12	11,600	82	109	16400	115	154
	5/8-11	14,500	113	151	20300	159	211
	3/4-10	21,300	200	266	30100	282	376
	7/8-9	29,435	321	430	41550	454	606
1-8	38,600	483	640	54540	680	900	
Unified Fine Thread Series	1/4 -28	2,300	85	115	3250	120	163
	5/16-24	3,700	173	230	5200	245	325
		lbs.	ft-lbs.	ft-lbs.	lbs.	ft-lbs.	ft-lbs.
	3/8-24	5,600	26	35	7900	37	50
	7/16-20	7,550	42	55	10700	59	78
	1/2-20	10,200	64	85	14400	90	120
	9/16-18	13,000	92	122	18300	129	172
	5/8-18	16,300	128	170	23000	180	240
	3/4-16	23,800	223	298	33600	315	420
	7/8-14	32,480	355	473	45855	500	668
1-12	42,270	528	704	59670	745	995	

Table 3-4: Torque specifications for SAE fasteners



Nominal Thread Size	 Grade 8.8			 Grade 10.9			 Grade 12.9		
	Clamp Load	Tightening Torque		Clamp Load	Tightening Torque		Clamp Load	Tightening Torque	
		K = .15	K = .20		K = .15	K = .20		K = .15	K = .20
mm	lbs.	in-lbs.	in-lbs.	lbs.	in-lbs.	in-lbs.	lbs.	in-lbs.	in-lbs.
3	-	-	-	-	-	-	823	14.6	19.5
3.5	-	-	-	-	-	-	1,109	22.9	30.5
4	-	-	-	-	-	-	1,436	33.9	45.2
5	1,389	41.0	19.5	1,987	58.7	19.5	2,322	68.6	91.2
6	1,966	69.7	28.3	2,813	100.0	28.3	3,287	116.8	155.8
7	2,826	116.8	37.2	4,044	167.3	37.2	4,727	195.6	260.2
		ft-lbs.	ft-lbs.		ft-lbs.	ft-lbs.		ft-lbs.	ft-lbs.
8	3,579	14.1	18.8	5,122	20.1	26.9	5,986	23.6	31.4
10	11,742	27.9	37.2	8,117	39.9	53.3	9,486	46.7	62.3
12	8,244	48.7	64.9	11,797	69.7	92.2	13,787	81.1	108.4
14	11,246	77.4	103.3	16,093	110.6	147.5	18,808	129.1	172.6
16	15,883	125.4	166.7	21,971	173.3	230.9	25,677	202.1	269.2
18	19,424	171.9	229.4	26,869	238.2	317.2	31,401	278.1	371.0
20	2,304	243.4	325.3	34,286	337.8	449.9	40,070	394.6	525.9
22	30,653	331.9	442.5	42,403	458.8	612.2	49,556	536.2	715.4
24	35,711	420.4	562.0	49,400	583.4	778.1	57,733	682.2	909.4
27	46,435	617.3	84.8	64,235	853.4	1138.1	75,069	997.2	1329.8
30	56,753	837.9	1117.4	78,509	1159.4	1545.2	91,751	1354.9	1807.0
33	70,208	1140.3	1520.1	97,121	1576.9	2102.8	113,503	1843.9	2457.5
36	82,651	1464.1	1952.3	114,334	2025.3	2700.9	133,620	2367.6	3156.0

Table 3-5: Torque specifications for metric fasteners, U.S. customary units

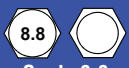
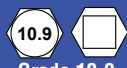

Nominal Thread Size	 Grade 8.8			 Grade 10.9			 Grade 12.9		
	Clamp Load	Tightening Torque		Clamp Load	Tightening Torque		Clamp Load	Tightening Torque	
		K = .15	K = .20		K = .15	K = .20		K = .15	K = .20
mm	N	N-m	N-m	N	N-m	N-m	N	N-m	N-m
3	-	-	-	-	-	-	3,660	1.65	2.2
3.5	-	-	-	-	-	-	4,932	2.59	3.45
4	-	-	-	-	-	-	6,387	3.83	5.11
5	6,177	4.63	2.2	8,840	6.63	2.2	10,330	7.75	10.3
6	8,743	7.87	3.2	12,512	11.3	3.2	14,623	13.2	17.6
7	12,570	13.2	4.2	17,990	18.9	4.2	21,025	22.1	29.4
8	15,921	19.1	25.5	22,784	27.3	36.5	26,626	32	42.6
10	25,230	37.8	50.5	36,105	54.1	72.2	42,195	63.3	84.4
12	36,670	66	88	52,475	94.5	125	61,328	110	147
14	50,025	105	140	71,587	150	200	83,663	175	234
16	70,650	170	226	97,732	235	313	114,218	274	365
18	86,400	233	311	119,520	323	430	139,680	377	503
20	10,250	330	441	152,513	458	610	178,238	535	713
22	136,350	450	600	188,618	622	830	220,433	727	970
24	158,850	570	762	219,743	791	1055	256,808	925	1233
27	206,550	837	115	285,728	1157	1543	333,923	1352	1803
30	252,450	1136	1515	349,223	1572	2095	408,128	1837	2450
33	312,300	1546	2061	432,015	2138	2851	504,885	2500	3332
36	367,650	1985	2647	508,582	2746	3662	594,368	3210	4279

Table 3-6: Torque specifications for metric fasteners, SI units

TROUBLESHOOTING

CONTENTS

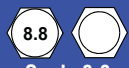
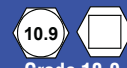
INTRODUCTION	4-2
GENERAL PROCEDURE	4-2
TROUBLESHOOTING PROCEDURE	4-2
SPECIAL TOOLS	4-2
ADJUSTMENT PROCEDURES	4-3
CHECKING PUMP PRESSURES	4-3
TROUBLESHOOTING GUIDE	4-3
DIAGNOSTICS	4-4
SYSTEM	4-4
PLATFORM	4-4
GROUND	4-4
INPUTS	4-4
ANALOGS	4-4
OUTPUTS	4-4
SL26-30 I/O LIST	4-5
GP400 I/O	4-5
PLATFORM MATRIX I/O	4-7

TROUBLESHOOTING

INTRODUCTION

The following section on troubleshooting provides guidelines on the types of problems users may encounter in the field. This helps to determine the cause of problems and provides suggestions for proper corrective action.

Careful inspection and accurate analysis of the symptoms listed in the troubleshooting guide will localize the trouble more quickly than any other method. This manual cannot cover all possible problems that may occur. If a specific problem is not covered in this manual, call Snorkel for service assistance.

Referring to section 2 and 5 will aid in understanding the operation and function of the various components and systems helping in diagnosing and repairing of the machine.

GENERAL PROCEDURE

It is important to thoroughly study the hydraulic and electrical schematics in section 5.

- Check for loose connections and short circuits.
- Check/repair/replace each component that does not operate properly using the Truth table listed under each machine function.
- Use the information provided in this section to help determine the cause of a fault.

NOTE: Spike protection diodes on components have been left out to eliminate confusion.

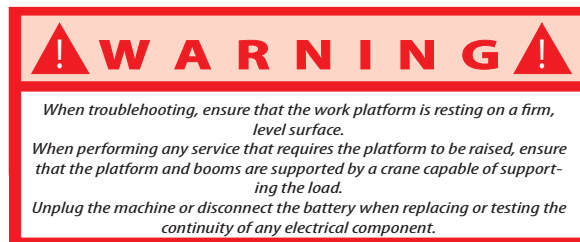

TROUBLESHOOTING PROCEDURE

1. Verify the problem: Perform a full function test from both the platform and chassis controls and note all functions that are not operating correctly.
2. Narrow the possible causes: Use the troubleshooting guide to determine which components are common to all circuits that are not functioning correctly.
3. Identify the problem component: Test components that are common to all circuits that are not functioning correctly. Remember to check wires and terminals between suspected components. Be sure to check connections to the battery negative terminal.
4. Repair or replace any component found to be faulty.
5. Verify that repair is complete: Do a full function test from both the platform and chassis controls to verify that all functions are operating correctly and that the machine is performing to specific values.

SPECIAL TOOLS

The following is a list of tools which may be required to perform certain maintenance procedures on the SL-series work platforms.

- 0-45 bar (0-600 psi) hydraulic pressure gauge with adapter fittings.
- 0-250 bar (0-3500 psi) hydraulic pressure gauge with adaptor fittings
- Mini mess hydraulic test point fittings.
- Inclinator
- Crimping tools, STD insulated and Deutsch
- EZcal calibrator (Snorkel part number: 504560-001)

ADJUSTMENT PROCEDURES

Hydraulic settings must be checked whenever a component is repaired or replaced.

- Do not remove the counterbalance valves and “bench test” them if they are faulty.
- Only replace them with valves of the same type.
- Connect a pressure gauge of appropriate range to the test port located on the hydraulic manifold.
- Correct pressure settings are listed in the hydraulic schematic.

CHECKING PUMP PRESSURES

Remove hose from manifold pump port and connect pressure gauge.

TROUBLESHOOTING GUIDE

Trouble	Probable Cause	Remedy
All functions do not operate, engine does not start.	Faulty battery.	After completely charging batteries, test each battery. Replace if necessary.
	Loose or broken battery lead.	Check continuity of all battery and motor leads. Replace if necessary.
	Emergency stop switch/switches failed to open.	With emergency stop switch in the “ON” position, check continuity.
Loss of hydraulic power with engine “ON”.	Oil level in hydraulic reservoir is low.	Check hydraulic fluid level and top up as required.
	Faulty hydraulic pump.	Check pressure and delivery of the hydraulic oil. Replace if necessary.
Loss of electrical power with engine “ON” and hydraulic power available.	Emergency lowering valve open	Close emergency lowering valve.
	Platform overloaded and alarm sounds.	Observe maximum load rating (refer to operation section of this manual).
	Faulty controller at upper controls.	Check functionality of controller. Replace if faulty.
	Battery level low.	Check battery voltage. Charge the battery if necessary.
Platform drifts down	Emergency lowering valve opened.	Ensure that the emergency lowering valve is completely closed. Replace if necessary.
	Leaking piston seals in lift cylinders	Check for leakage at cylinder return line. Replace seals if necessary.

TROUBLESHOOTING

DIAGNOSTICS

The EZcal display has a number of diagnostic tools to aid troubleshooting. To access these with the machine switched on, press and hold "ESC" for 5 seconds until "#### MENU: HELP: PRESS ENTER" is displayed. Press "ENTER" for a top level fault message.

For more detailed diagnostics from the top menu, scroll right to "DIAGNOSTICS" and press "ENTER". A list of diagnostics sub menus become available as follows:

SYSTEM

The information listed below is relevant to this machine (ignore any other data).

- MODE: Ground or platform mode selected.
- SUPPLY: The supply voltage at the GP400.
- VALVE SUPPLY: Valve supply "ON" or "OFF".
- TILT: This is the platform tilt angle in X and Y.
From tilt, press "ENTER" for chassis tilt angle in X and Y.
- AXLE: Press "ENTER" for "AXLE Tilt angle".
- TILTED: "YES" if the platform angle exceeds 2 degrees in X or Y.
- HEIGHT: The platform height as a percentage of full elevation.
- LOAD: The platform load as a percentage of full Safe Working Load (SWL).
- OVERLOADED: "YES" if the platform load exceeds 120% of the Safe Working Load (SWL).
- LAST MOVED: The last movement.
- ELEVATED: "YES" if the height is above the elevation height.

PLATFORM

The information listed below is relevant to this machine (ignore any other data).

- TRIGGER: "ON" if the joystick trigger is activated.
- JOYSTICK: Gives the percentage of joystick deflection.
- FWD/UP: "ON" if the joystick is pushed forward beyond its "ON" position for "ON/OFF" applications eg "MANUAL LEVELLING" forwards.
- REV/DOWN: "ON" if the joystick is pulled backward beyond its "ON" position for "ON/OFF" applications eg. "MANUAL LEVELLING" backwards.
- LEFT: "ON" for steer left.
- Right: "ON" for steer right.

GROUND

The information listed below is relevant to this machine (ignore any other data).

- UP: "ON" for lift selected.
- DOWN: "ON" for lower selected.

INPUTS

This provides the condition for all digital inputs to the GP400 controller in the ground control box and the matrix board in the platform control box. Refer to the electrical circuit diagram and the I/O list for details of each input function.

ANALOGS

This provides the voltage on the analogue inputs to the GP400 controller in the ground control box and the MATRIX board in the platform control box. Refer to the electrical circuit diagram and the I/O list for details of each input function.

OUTPUTS

This provides the condition for all digital outputs from the GP400 controller in the ground control box and the MATRIX board in the platform control box. Refer to the electrical circuit diagram and the I/O list for details of each output function.

SL26-30 I/O LIST

GP400 I/O

Key	Meaning
MM	Movement Manifold Block
DM	Drive manifold Block
***	Elevated drive is always low speed

Connector-pin	I/O type	Function CE	Function ANSI	Comment
P7-1	B+	TBM positive	TBM positive	Powers valve outputs, does not power GP400
P8-14	B-	TBM negative	TBM negative	
P7-2	B+ digital input	Key switch ground mode	Key switch ground mode	High selects ground control and powers GP400
P7-4	B+ digital input	Key switch platform mode	Key switch platform mode	High selects platform control and powers GP400
P7-3	B+ digital input	Ground enable	Ground enable	Enables ground controlled functions
P7-5	B+ digital input	Ground lift	Ground lift	Momentary: Hold to lift platform from ground controls when allowed
P7-6	B+ digital input	Ground lower	Ground lower	Momentary: Hold to lower platform from ground controls when allowed
P7-7	B+ digital input	Glow plug	Glow plug	Momentary: Hold for glow plug when ground control is selected
P7-8	B+ digital input	Engine start	Engine start	Momentary: Hold for engine start when ground control is selected
P8-13, P8-15	0 V for sensors	Sensor ground	Sensor ground	Ground to 2 off EZfit & Pressure transducer.
P8-2	Analogue input	EZfit #1	EZfit #1	From EZfit #1 output
P8-5	Analogue input	EZfit #2	EZfit #2	From EZfit #2 output
P8-6	Analogue input	Pressure transducer	NOT USED	From pressure transducer output CE ONLY
P8-9	Analogue input	TBM current sense	TBM current sense	From TBM
P7-14	B- digital input	Engine coolant temperature sensor	Engine coolant temperature sensor	Low input prevents engine starting and/or running
P7-13	B- digital input	Engine oil pressure sensor	Engine oil pressure sensor	Low input: Will allow engine start but sound alarm immediately and kill engine if low for > 30 seconds
P7-15	B- digital input	Low if alternator fails to charge	Low if alternator fails to charge	Low input: Will allow engine start but sound alarm immediately and kill engine if low for > 30 seconds

TROUBLESHOOTING

GP400 I/O

Connector-pin	I/O type	Function CE	Function ANSI	Comment
P4-7	High side 2 A output	Throttle relay	Throttle relay	Energise for high revs
P4-1	High side PWM output	Proportional valve - MM:SP1	Proportional valve - MM:SP1	Analogue output to proportional valve
P4-8	High side 2 A output	Engine enable	Engine enable	High when engine start/run is allowed
P4-4	High side 2 A output	Glow plug relay	Glow plug relay	High to active glow plug relay
P4-5	High side 2 A output	Engine start solenoid relay	Engine start solenoid relay	High to turn engine starter motor
P5-2	High side 2 A output	Steer left solenoid - MM:SV1a	Steer left solenoid - MM:SV1a	To steer left energise MM:SV1a & MM:SV4
P5-3	High side 2 A output	Steer right solenoid - MM:SV1b	Steer right solenoid - MM:SV1b	To steer right energise MM:SV1b & MM:SV4
P5-7	High side 2 A output	Platform tilt left sol - MM:SV2a	Platform tilt left sol - MM:SV2a	To tilt platform left energise MM:SV2a & MM:SV4
P5-8	High side 2 A output	Platform tilt right sol - MM:SV2b	Platform tilt right sol - MM:SV2b	To tilt platform right energise MM:SV2b & MM:SV4
P5-9	High side 2 A output	Platform tilt forward sol - MM:SV3a	Platform tilt forward sol - MM:SV3a	To tilt platform forward energise MM:SV3a & MM:SV4
P5-11	High side 2 A output	Platform tilt backwards sol - MM:SV3b	Platform tilt backwards sol - MM:SV3b	To tilt platform backwards energise MM:SV3b & MM:SV4
P5-15	High side 2 A output	Tilt/Steer dump solenoid - MM:SV4	Tilt/Steer dump solenoid - MM:SV4	Energise to allow platform levelling and steering
P4-14	High side 2 A output	Lift solenoid - MM:SV5	Lift solenoid - MM:SV5	To lift platform energise MM:SV5 and proportional valve MM:SP1
P4-13	High side 2 A output	Lower solenoid	Lower solenoid	Energise to lower the platform *Solenoid on lift cylinder
P4-2	High side 2 A output	Drive forward sol - DM:SV01a	Drive forward sol - DM:SV01a	For low speed forward drive energise DM:SV01a and proportional valve MM:SP1 ***
P4-6	High side 2 A output	Drive reverse sol - DM:SV01b	Drive reverse sol - DM:SV01b	For low speed reverse drive energise DM:SV01b and proportional valve MM:SP1 ***
P4-3	High side 2 A output	Medium speed sol - DM:SV4	Medium speed sol - DM:SV4	For medium speed drive energise DM:SV4 & DM:SV8 and select forward/reverse with DM:SV01a/DM:SV01b and proportional valve MM:SP1
P5-14	High side 2 A output	High speed sol - DM:SV5	High speed sol - DM:SV5	For high speed drive energise DM:SV5, DM:SV8, DM:SV11 & DM:SV13 and select forward/reverse with DM:SV01a/DM:SV01b and proportional valve MM:SP1
P4-9	High side 2 A output	2 wheel drive sol - DM:SV8	2 wheel drive sol - DM:SV8	Energised for high & medium speed drive
P4-10	High side 2 A output	Series drive sol - DM:SV11	Series drive sol - DM:SV11	Energised for high speed drive

GP400 I/O

Connector-pin	I/O type	Function CE	Function ANSI	Comment
P5-1	High side 2 A output	High speed sol - DM:SV13	High speed sol - DM:SV13	Energised for high speed drive
P4-15	High side 2 A output	Axle float solenoid	Axle float solenoid	Energise when driving and NOT elevated to allow axle float *Solenoid on axle float cylinder
P5-5	High side 2 A output	Ground alarm	Ground alarm	Alarm sounds as set in adjustments
P5-6	High side 2 A output	Overload LED	Not used	On when overloaded (CE only)

PLATFORM MATRIX I/O

Connector-pin	I/O type	Function CE	Function ANSI	Comment
MP3-1	Mux digital input	Common for selector switches	Common selector switches	
MP3-1/4	Mux digital output	Drive high speed select	Drive high speed select	Momentary switch latches high speed drive function
MP3-1/5	Mux digital output	Drive medium speed select	Drive medium speed select	Momentary switch latches medium speed drive function
MP3-1/6	Mux digital output	Drive low speed select	Drive low speed select	Momentary switch latches low speed drive function
MP3-1/7	Mux digital output	Auto level	Auto level	Momentary: Hold (along with joystick trigger) for Auto platform level. Auto level only allowed when the platform is below elevated height and the chassis tilt is within preselected chassis tilt limits.
MP3-1/8	Mux digital output	Lift/Lower select	Lift/Lower select	Momentary switch latches platform lift/lower function
MP3-1/9	Mux digital output	Glow plug	Glow plug	Momentary: Hold for glow plug when platform control is selected
MP3-1/10	Mux digital output	Engine start	Engine start	Momentary: Hold for engine start when platform control is selected & engine start allowed.
MP4-1	Low side 1 A output	Overload LED	Not used	Flash & steady "ON" when overload dependant on adjustment setting (CE only)
MP4-2	Low side 1 A output	Drive high speed select LED	Drive high speed select LED	Steady on when high speed drive is selected
MP4-3	Low side 1 A output	Drive medium speed select LED	Drive medium speed select LED	Steady on when medium speed drive is selected
MP4-4	Low side 1 A output	Drive low speed select LED	Drive low speed select LED	Steady on when low speed drive is selected
MP4-5	Low side 1 A output	Lift/Lower select LED	Lift/Lower select LED	Steady on when platform lift/lower is selected

TROUBLESHOOTING

PLATFORM MATRIX I/O

Connector-pin	I/O type	Function CE	Function ANSI	Comment
MP4-6	Low side 1 A output	Tilt LED	Tilt LED	Flash when platform is tilted beyond platform tilt limits.
MP4-7	Low side 1 A output	Engine LED	Engine LED	Steady on when GP400 P7-13,14, or 15 are low.
MP4-8	Low side 1 A output	Buzzer	Buzzer	Alarm sounds as set in adjustments
MP2-1	B+ digital input	Steer left switch	Steer left switch	Activate left steer when drive is allowed and trigger closed
MP2-2	B+ digital input	Steer right switch	Steer right switch	Activate right steer when drive is allowed and trigger closed
MP2-5	B+ digital input	Trigger switch	Trigger switch	Trigger enable from joystick
MP2-7	Analogue input	Joystick	Joystick	Joystick hall effect output
MP2-10	5 V protected supply	Joystick	Joystick	Joystick hall effect supply
MP2-11	B- protected supply	Joystick	Joystick	Joystick hall effect gnd
MP2-12	B+ protected supply	Joystick	Joystick	Joystick switches supply
MP1-1	B+ supply	CANTILT (x4)	CANTILT (x4)	2 off platform tilt sensors used for Auto level and to prevent drive and lift above the elevated height if platform is outside of preselected platform tilt limits & 2 off axle tilt sensors used to prevent lift and drive above the elevation height if the axle is out of level with the chassis by more than 1 degree. Connected in series over CAN and into the matrix board and GP400C.
MP1-3	CANH			
MP1-6	CANL			
MP1-4	GND			

SCHEMATICS

INTRODUCTION

This section contains electrical and hydraulic power schematics and associated information for maintenance purposes.

The diagrams are to be used in conjunction with the information in section 4. The schematics provide an understanding to the makeup and functions of the systems for checking, tracing and fault-finding during troubleshooting analysis.

CONTENTS

INTRODUCTION	5-1
ELECTRICAL SCHEMATIC CE - 514481-000	5-2
CABLE HARNESS SCHEMATICS - 514481-000	5-3
ENGINE - 514481-001	5-4
ELECTRICAL SCHEMATIC ANSI	5-5
HYDRAULIC SCHEMATIC	5-6

SCHEMATICS

ELECTRICAL SCHEMATIC CE - 514481-000

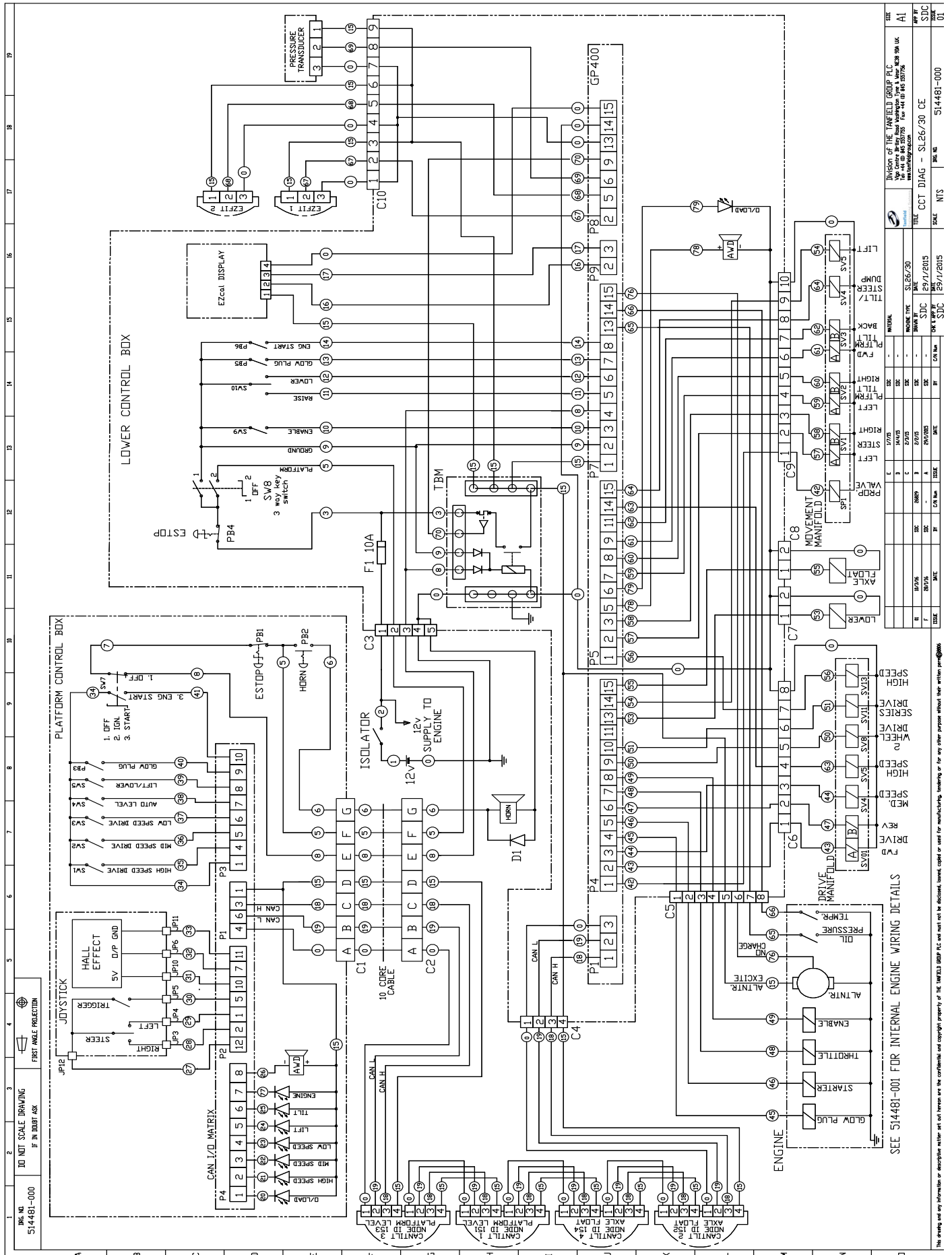

Division of THE FANFIELD GROUP PLC 100 Convent Road, West Washington, West, W8B 9BA, UK www.fanfieldgroup.com	THE CCT DIAG - SLE26/30 CE	DATE: 25/11/2015	SCALE: NTS	DWG NO: 514481-000	SHEET: 01
SIZE: A1	APP BY: SJC	CHK BY: SJC	DATE: 25/11/2015	SCALE: NTS	DWG NO: 514481-000
REV: 1	DATE: 25/11/2015	BY: SJC	CHK: SJC	SCALE: NTS	DWG NO: 514481-000
REV: 2	DATE: 25/11/2015	BY: SJC	CHK: SJC	SCALE: NTS	DWG NO: 514481-000
REV: 3	DATE: 25/11/2015	BY: SJC	CHK: SJC	SCALE: NTS	DWG NO: 514481-000
REV: 4	DATE: 25/11/2015	BY: SJC	CHK: SJC	SCALE: NTS	DWG NO: 514481-000
REV: 5	DATE: 25/11/2015	BY: SJC	CHK: SJC	SCALE: NTS	DWG NO: 514481-000
REV: 6	DATE: 25/11/2015	BY: SJC	CHK: SJC	SCALE: NTS	DWG NO: 514481-000
REV: 7	DATE: 25/11/2015	BY: SJC	CHK: SJC	SCALE: NTS	DWG NO: 514481-000
REV: 8	DATE: 25/11/2015	BY: SJC	CHK: SJC	SCALE: NTS	DWG NO: 514481-000
REV: 9	DATE: 25/11/2015	BY: SJC	CHK: SJC	SCALE: NTS	DWG NO: 514481-000
REV: 10	DATE: 25/11/2015	BY: SJC	CHK: SJC	SCALE: NTS	DWG NO: 514481-000

SEE 514481-001 FOR INTERNAL ENGINE WIRING DETAILS

The drawing and any information or description within it set herein are the confidential and copyright property of THE FANFIELD GROUP PLC and must not be disclosed, loaned, copied or used for any other purpose without their written permission.

CABLE HARNESS SCHEMATIC - 514481-000

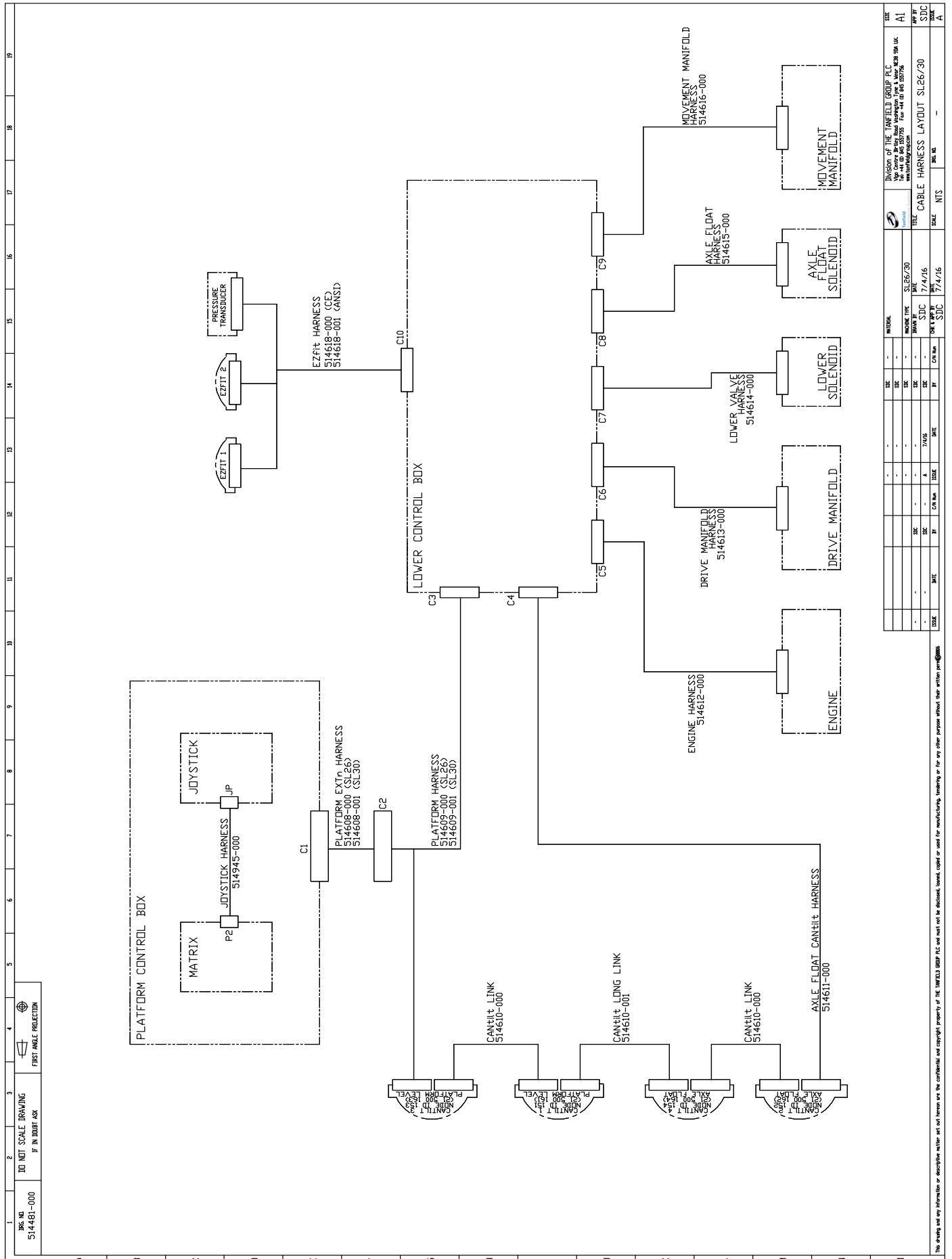

REV	DATE	BY	CHK'D	DATE	BY	CHK'D	DESCRIPTION
1							
2							
3							
4							
5							
6							
7							
8							
9							
10							
11							
12							
13							
14							
15							
16							
17							
18							
19							

REV	DATE	BY	CHK'D	DATE	BY	CHK'D	DESCRIPTION
1							
2							
3							
4							
5							
6							
7							
8							
9							
10							
11							
12							
13							
14							
15							
16							
17							
18							
19							

REV	DATE	BY	CHK'D	DATE	BY	CHK'D	DESCRIPTION
1							
2							
3							
4							
5							
6							
7							
8							
9							
10							
11							
12							
13							
14							
15							
16							
17							
18							
19							

REV	DATE	BY	CHK'D	DATE	BY	CHK'D	DESCRIPTION
1							
2							
3							
4							
5							
6							
7							
8							
9							
10							
11							
12							
13							
14							
15							
16							
17							
18							
19							

SCHEMATICS

ENGINE - 514481-001

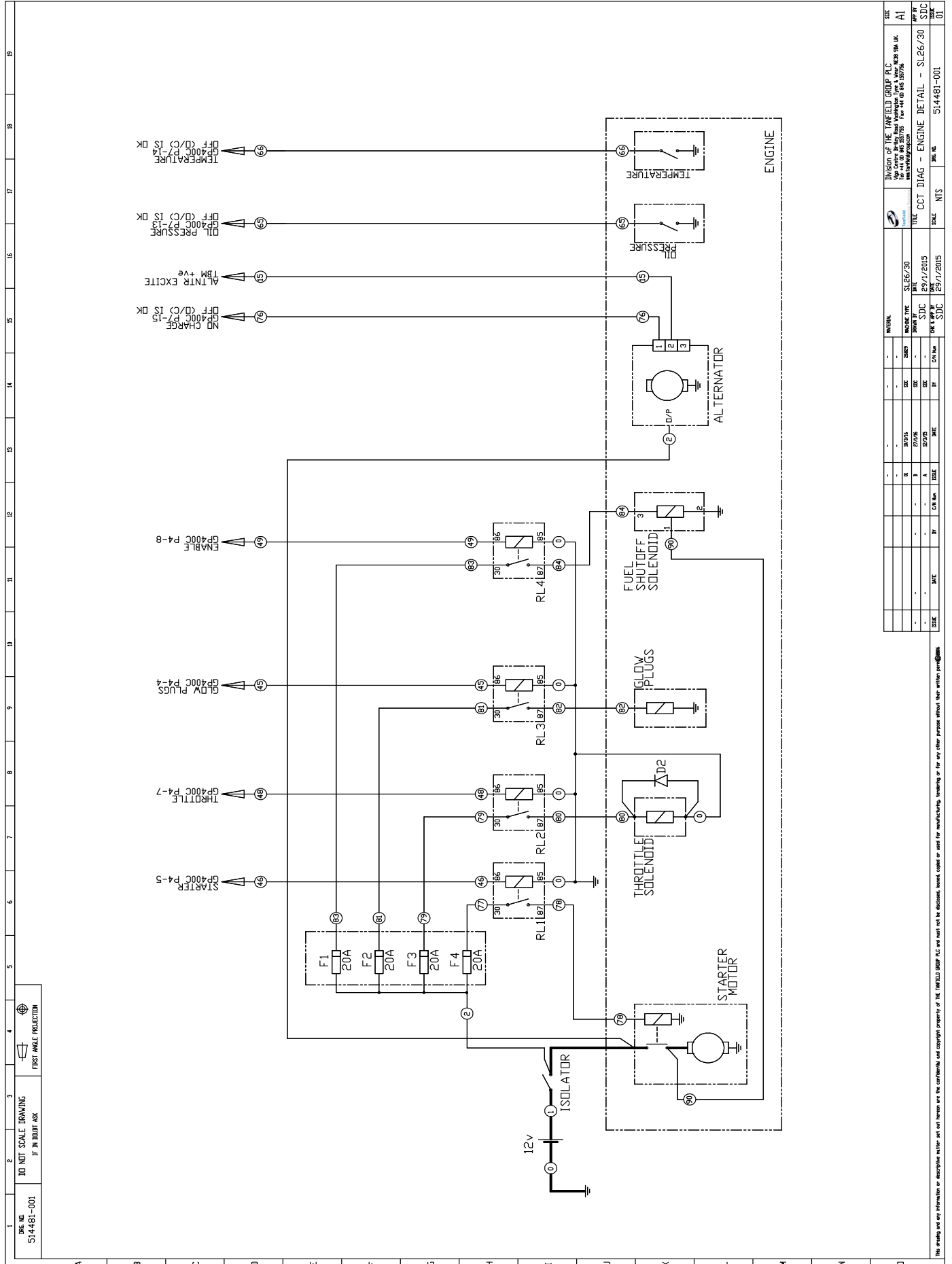

514481-001
 DIVISION OF THE FANFIELD GROUP PLC
 For use on the SL26/30
 Part of the SL26/30
 Part of the SL26/30

1 2 3 4 5 6 7 8 9 10 11 12 13 14 15 16 17 18 19

A B C D E F G H I J K L M N O

DO NOT SCALE DRAWING
 IF IN DOUBT ASK

FIRST ANGLE PROJECTION

REV	DATE	BY	CHK'D	APP'D	DESCRIPTION
1	29/11/2015	NTS	SDC	SDC	INITIAL
2	29/11/2015	NTS	SDC	SDC	REVISION
3	29/11/2015	NTS	SDC	SDC	REVISION
4	29/11/2015	NTS	SDC	SDC	REVISION
5	29/11/2015	NTS	SDC	SDC	REVISION
6	29/11/2015	NTS	SDC	SDC	REVISION
7	29/11/2015	NTS	SDC	SDC	REVISION
8	29/11/2015	NTS	SDC	SDC	REVISION
9	29/11/2015	NTS	SDC	SDC	REVISION
10	29/11/2015	NTS	SDC	SDC	REVISION
11	29/11/2015	NTS	SDC	SDC	REVISION
12	29/11/2015	NTS	SDC	SDC	REVISION
13	29/11/2015	NTS	SDC	SDC	REVISION
14	29/11/2015	NTS	SDC	SDC	REVISION
15	29/11/2015	NTS	SDC	SDC	REVISION
16	29/11/2015	NTS	SDC	SDC	REVISION
17	29/11/2015	NTS	SDC	SDC	REVISION
18	29/11/2015	NTS	SDC	SDC	REVISION
19	29/11/2015	NTS	SDC	SDC	REVISION

STARTER P4-5
 THROTTLE P4-7
 GLOW PLUGS P4-4
 ENABLE P4-8
 ND CHARGE P7-15
 ALTRNTR EXCITE
 TBM +ve
 DT. PRESSURE P7-13
 DFF (D/C) IS DK
 TEMPERATURE P7-14
 DFF (D/C) IS DK

12V
 ISOLATOR
 F1 20A
 F2 20A
 F3 20A
 F4 20A
 RL1
 RL2
 RL3
 RL4
 THROTTLE SOLENOID
 GLOW PLUGS
 FUEL SHUTOFF SOLENOID
 STARTER MOTOR
 ALTERNATOR
 ENGINE
 PRESSURE
 TEMPERATURE

514481-001
 DIVISION OF THE FANFIELD GROUP PLC
 For use on the SL26/30
 Part of the SL26/30
 Part of the SL26/30

SL26/30SL

Page 5 - 4

ELECTRICAL SCHEMATIC ANSI - 514481-002

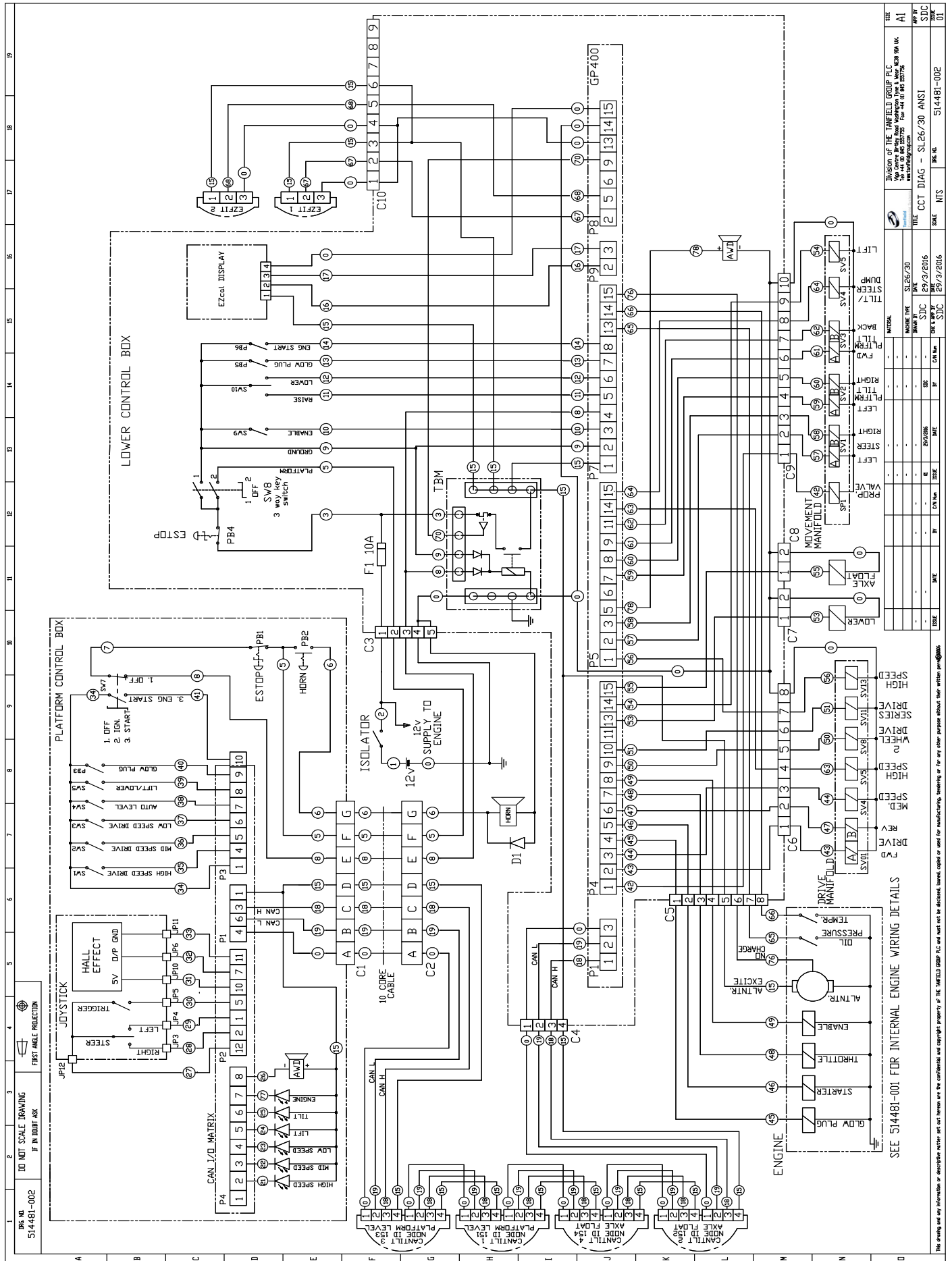

REV	DATE	BY	CHK	APP	DESCRIPTION
01	29/3/2016	NTS	SDC	SDC	REVISED

REV	DATE	BY	CHK	APP	DESCRIPTION
01	29/3/2016	NTS	SDC	SDC	REVISED

REV	DATE	BY	CHK	APP	DESCRIPTION
01	29/3/2016	NTS	SDC	SDC	REVISED

REV	DATE	BY	CHK	APP	DESCRIPTION
01	29/3/2016	NTS	SDC	SDC	REVISED

REV	DATE	BY	CHK	APP	DESCRIPTION
01	29/3/2016	NTS	SDC	SDC	REVISED

REV	DATE	BY	CHK	APP	DESCRIPTION
01	29/3/2016	NTS	SDC	SDC	REVISED

REV	DATE	BY	CHK	APP	DESCRIPTION
01	29/3/2016	NTS	SDC	SDC	REVISED

REV	DATE	BY	CHK	APP	DESCRIPTION
01	29/3/2016	NTS	SDC	SDC	REVISED

REV	DATE	BY	CHK	APP	DESCRIPTION
01	29/3/2016	NTS	SDC	SDC	REVISED

SEE 514481-001 FOR INTERNAL ENGINE WIRING DETAILS

Division of THE TAFE GROUP PLC
 The Centre for the Region's Skills Development
 100 South Street, West Perth, WA 6005
 www.tafegroup.com.au

PROJECT: CCT DIAG - SL26/30 ANSI
 DRAWN BY: NTS
 CHECKED BY: SDC
 DATE: 29/3/2016

ILLUSTRATED PARTS LIST

INTRODUCTION

This section lists and illustrates the replaceable assemblies and parts of this product as manufactured by Snorkel.

Each part list contains the component parts for that assembly.

CONTENTS

GENERAL ASSEMBLY	6-2	ELECTRICAL ASSEMBLY - CABLE ASSEMBLIES	6-38
CHASSIS ASSEMBLY	6-3	ELECTRICAL ASSEMBLY - EXTERNAL COMPONENTS	6-39
ELEVATING ASSEMBLY	6-5	CABLE HARNESS SCHEMATICS - 514481-000	6-40
PLATFORM ASSEMBLY	6-7	DECAL ASSEMBLY	6-41
PLATFORM ASSEMBLY - SLIDE OUT SECTION	6-10	DECAL KIT SL30SL - ENGLISH	6-42
ENGINE ASSEMBLY	6-12	DECAL KIT SL26SL - ENGLISH	6-43
ENGINE CABINET ASSEMBLY	6-14		
CONTROL MODULE ASSEMBLY	6-16		
HYDRAULIC VALVE BLOCK MOVEMENT	6-18		
HYDRAULIC VALVE BLOCK DRIVE	6-19		
LOWER CONTROL PANEL ASSEMBLY - CE	6-20		
LOWER CONTROL PANEL ASSEMBLY - ANSI	6-22		
UPPER CONTROL PANEL ASSEMBLY - CE	6-24		
UPPER CONTROL PANEL ASSEMBLY - ANSI	6-26		
UPPER CONTROL PANEL ASSEMBLY - ADDITIONS	6-28		
HYDRAULIC OIL TANK ASSEMBLY	6-29		
FUEL TANK ASSEMBLY - DIESEL	6-30		
HYDRAULIC HOSE ASSEMBLY	6-31		
HYDRAULIC CYLINDER ASSEMBLY - MAIN LIFT	6-34		
STEER, AXLE FLOAT & TILT CYLINDER	6-35		
ELECTRICAL ASSEMBLY - PLATFORM CONTROL BOX	6-36		
ELECTRICAL ASSEMBLY - GROUND CONTROL PANEL	6-37		

ILLUSTRATED PARTS LIST

GENERAL ASSEMBLY

ITEM	PART	DESCRIPTION	QTY
1	505503-000	Platform assembly	1
2	505501-000	Chassis assembly	1
3	505502-000	Elevating assembly	1
4	505504-000	Power module	1
5	505515-000	Control module	1

Table 6-1: SL30SL - 505500-000

ITEM	PART	DESCRIPTION	QTY
1	505603-000	Platform assembly	1
2	505501-000	Chassis assembly	1
3	505602-000	Elevating assembly	1
4	505504-000	Power module	1
5	505515-000	Control module	1

Table 6-2: SL30SL - 505600-000

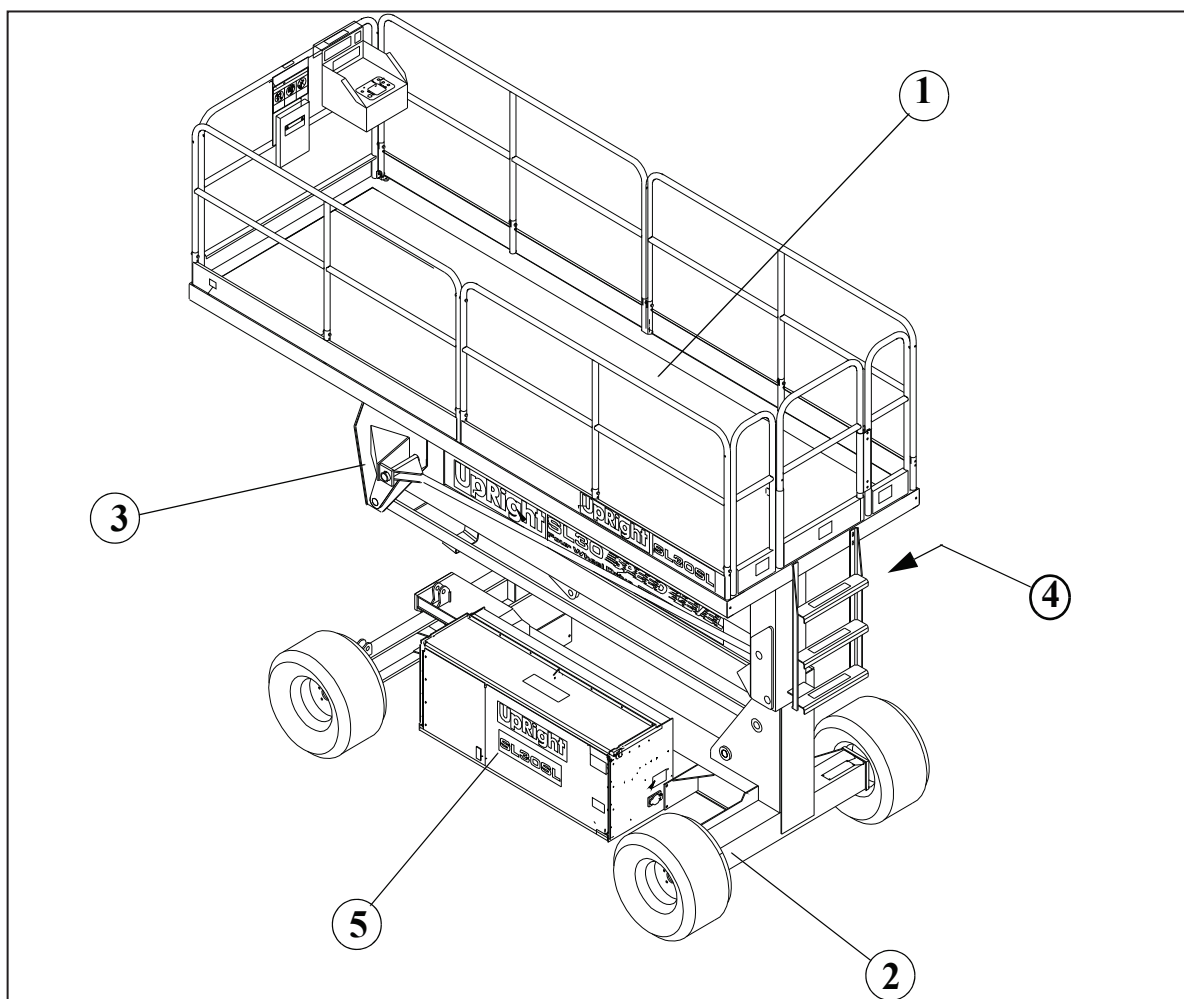

Figure 6-1: General assembly of SL26/30SL

CHASSIS ASSEMBLY

ITEM	PART	DESCRIPTION	QTY
1	064320-001	Weldment, 1st post	1
2	064331-001	Weldment, level pivot	1
3	510501-000	Weldment, chassis	1
4	510497-000	Weldment, front axle	1
5	064343-001	Trunnion	2
6	011256-014	Screw, trunnion	8
7	011238-008	Washer	8
8	064383-000	Thrust washer, 5 mm	4
	064383-001	Thrust washer, 4 mm	4
	064383-002	Thrust washer, 3 mm	4
9	062642-032	Bushing, level pivot	4
10	064811-000	Hub, rear	2
11	011754-012	Split pin	4
12	98300-9	Wheel bolt	20
13	069129-000	Wheel, right hand	2
	069129-002	Wheel, right hand ANSI	2
14	069129-001	Wheel, left hand	2
	069129-003	Wheel, left hand ANSI	2
15	505201-000	Drive motor, rear	2
16	011257-014	Bolt, drive motor, rear	8
17	063905-101	Cylinder, steer	1
18	512318-000	Bushing, axle/Motor mount	2
19	510333-000	Steering link arm	2
20	505564-000	Motor mount	2
21	505202-000	Drive motor, front	2
22	064812-000	Hub, front	2
23	027931-057	Bushing, roller	2
24	011754-012	Split pin	4
25	064350-000	Axle pivot	2
26	509463-000	Top axle pin	2
27	062642-001	Bushing, motor mount	4
28	063927-001	Rose bearing, steering cylinder	2
29	064298-005	Bushing, axle to chassis	2
30	064336-000	Pivot pin, front axle	1
31	508020-000	Pivot pin, float cylinder axle	2
32	064346-100	Cylinder, chassis - axle	1
33	514482-002	CANTILT sensor ID152	1
34	514482-004	CANTILT sensor ID154	1
35	064339-001	Pin, 1st post/Level pivot/Chassis	1

ITEM	PART	DESCRIPTION	QTY
36	508021-000	Pin, level cylinder - 1st post	4
37	064345-100	Cylinder, float	2
38	509445-000	Bearing spacer	4
39	064349-000	Bearing spacer	4
40	505046-000	Nut, steering linkage	4
41	057052-130	Bolt, front motor mount	4
42	056069-012	Washer, front motor	4
43	011238-005	Washer, rear motor	4
44	056064-012	Nut, front motor	4
45	064347-000	Level cover plate	1
46	064384-000	Channel	1
47	509462-000	Bottom axle pin	2
48	011782-001	Bearing thrust washer	2
49	064294-004	Actuator lever	1
50	15-0489	Location pad	1
51	503995-000	Bracket, proximity switch	1
52	509535-000	Axle spacers 6 mm	8
53	011257-024	Bolt, 5/8 x 3" UNC HHC	4
54	514482-001	CANTILT sensor ID151	1
55	514482-003	CANTILT sensor ID153	1

Table 6-3: SL26/30SL - 505501-000

NOTE: When ordering CANTILT sensors, take note of the part number printed on the sensor and take care when ordering using the correct Snorkel part number. Ensure to cross reference the number with that given in the table.

ILLUSTRATED PARTS LIST

CHASSIS ASSEMBLY

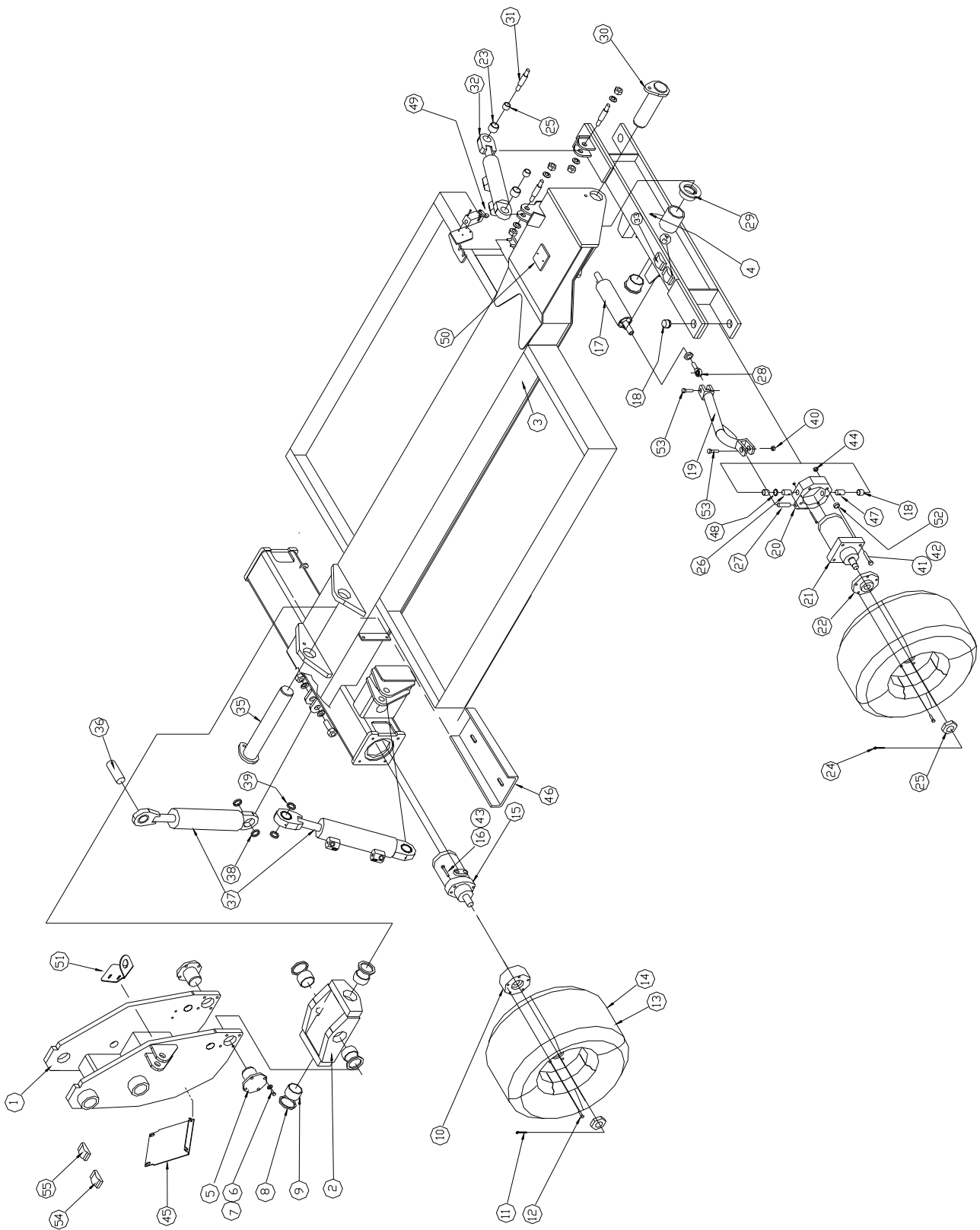

Figure 6-2: Chassis assembly of SL26/30SL

ELEVATING ASSEMBLY

ITEM	PART	DESCRIPTION	QTY
1	011254-024	Bolt, Pin lock 3/8'	9
2	064090-000	Pivot pin, upper T-bar & up boom - PED	3
3	011248-006	Nut, pin lock 3/8'	9
4	064111-002	Weldment, pedestal (platform supplement)	1
5	062649-020	Bushing, all 1.75" pins	12
6	064536-000	Upper tension bar	1
7	064521-000	Upper boom	1
8	064538-000	Channel, wire cover (upper boom)	1
9	062642-030	Bushing, all 2.75 pins	6
10	011248-016	Locknut 1'	6
11	064089-000	Gear segment	2
12	013336-001	Grease nipple (1/8 BSP)	16
13	064070-002	2nd Post weldment	1
14	064094-000	Pivot pin, lower T-bar	2
15	062649-010	Bushing, lift cylinder rod - boom	2
16	011248-016	Nut (roller)	1
17	064095-000	Pivot pin, lower boom & upper boom - 2nd	3
18	064530-000	Lower boom	1
19	064542-000	Channel, wire cover (lower boom)	1
20	064093-000	Pivot pin, cylinder rod - lower boom	1
21	064531-001	Lower tension bar	1
22	014918-048	Bolt (roller, boom rest)	1
23	064356-000	Roller pin	1
24	027931-057	Bushing, roller	2
25	064354-000	Roller	1
26	063904-101	Cylinder, main lift	1
27	064320-001	1st post weldment	1
28	064331-001	Leveller weldment	1
29	064094-000	Pivot pin, cylinder body - 1st post	1
30	014918-056	Bolt, 1" - 8 UNC x 7"	6
31	504559-000	Overload EZfit angle transducer	2
32	504560-000	Overload 3000 PSI pressure transducer	1

Table 6-4: SL30SL - 505502-000

ITEM	PART	DESCRIPTION	QTY
1	011254-024	Bolt, Pin lock 3/8'	9
2	064090-000	Pivot pin, upper T-bar & up boom - PED	3
3	011248-006	Nut, pin lock 3/8'	9
4	064111-001	Weldment, pedestal (platform supplement)	1
5	062649-020	Bushing, all 1.75" pins	12
6	064087-000	Upper tension bar	1
7	064078-002	Upper boom	1
8	064451-000	Channel, wire cover (upper boom)	1
9	062642-030	Bushing, all 2.75 pins	6
10	011248-016	Locknut 1'	6
11	064089-000	Gear segment	2
12	013336-001	Grease nipple (1/8 BSP)	16
13	064070-002	2nd Post weldment	1
14	064094-000	Pivot pin, lower T-bar	2
15	062649-010	Bushing, lift cylinder rod - boom	2
16	011248-016	Nut (roller)	1
17	064095-000	Pivot pin, lower boom & upper boom - 2nd	3
18	064060-003	Lower boom	1
19	064450-000	Channel, wire cover (lower boom)	1
20	064093-000	Pivot pin, cylinder rod - lower boom	1
21	064084-001	Lower tension bar	1
22	014918-048	Bolt (roller, boom rest)	1
23	064356-000	Roller pin	1
24	027931-057	Bushing, roller	2
25	064354-000	Roller	1
26	063904-101	Cylinder, main lift	1
27	064320-001	1st post weldment	1
28	064331-001	Leveller weldment	1
29	064094-000	Pivot pin, cylinder body - 1st post	1
30	014918-056	Bolt, 1" - 8 UNC x 7"	6
31	504559-000	Overload EZfit angle transducer	2
32	504560-000	Overload 3000 PSI pressure transducer	1

Table 6-5: SL26SL - 505602-000

ILLUSTRATED PARTS LIST

ELEVATING ASSEMBLY

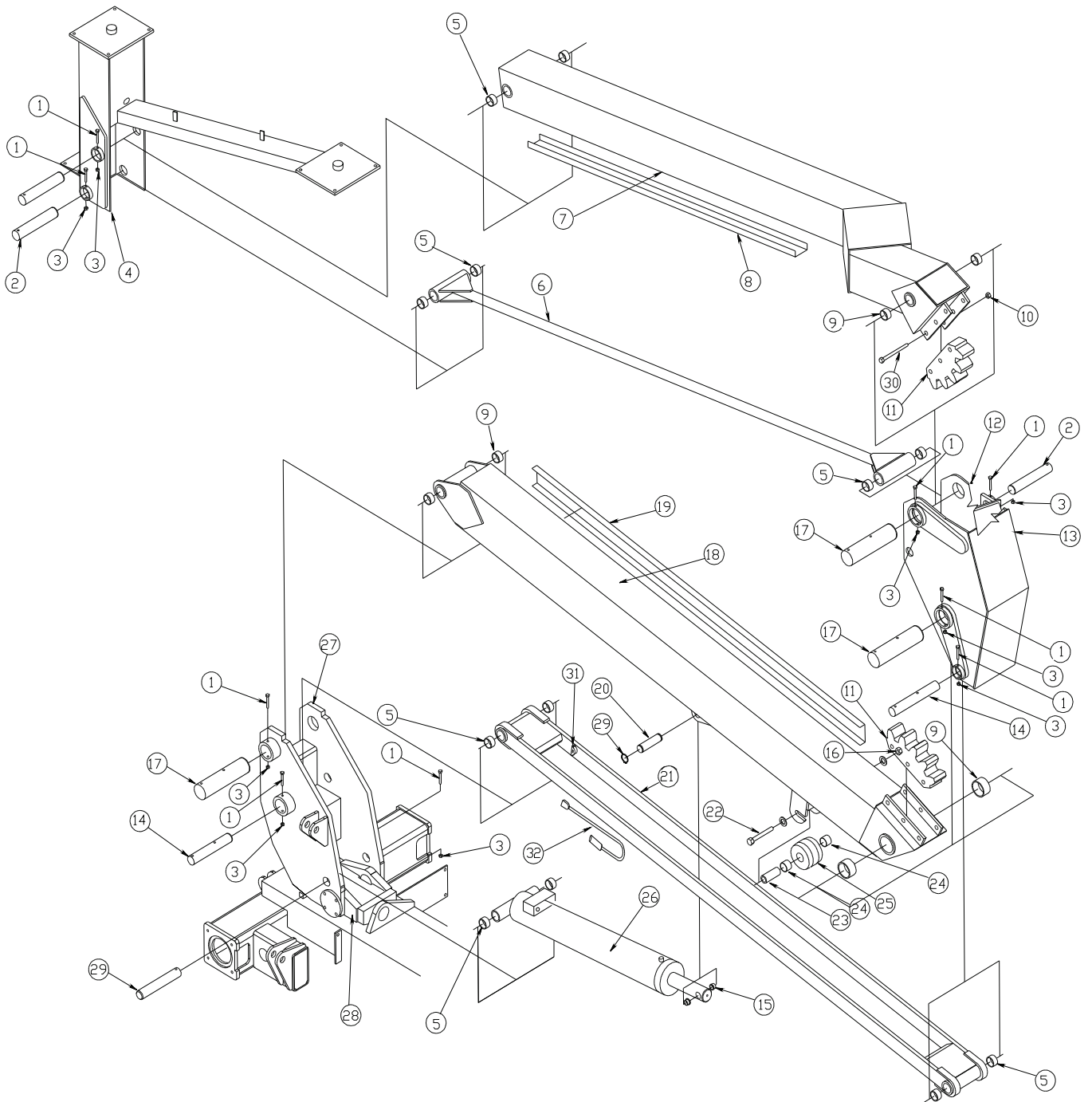

Figure 6-3: Elevating assembly of SL26/30SL

PLATFORM ASSEMBLY

ITEM	PART	DESCRIPTION	QTY
1	064540-011	Deck weldment	1
2	510502-000	Ladder weldment	1
3	064111-002	Pedestal weldment	1
4	510678-000	Safe deck mounting	30
5	064700-000	Guardrail, front	1
6	064696-000	Kick plate, side	4
7	064698-000	Guardrail, side	4
8	064702-002	Guardrail, end left hand side	1
9	064702-001	Guardrail, end right hand side	1
10	067764-001	Kick plate, gate	1
11	067883-000	Gate weldment	1
12	067712-000	Gate pivot tube	1
13	003570-005	Plunger assembly	1
14	062642-026	Bushing, gate pivot	2
15	066526-004	Gate spring	1
16	064688-001	Pivot bracket RH	2
17	064688-002	Pivot bracket LH	2
18	064447-000	Skirt plate (rubber skirt)	1
19	064448-000	Rubber skirt	1
20	067695-000	Spacer, guardrail	6
21	064046-000	Rail mounting bracket	2
22	010076-000	Manual box (Black plastic)	1
23	510677-000	Safe deck, aluminium stabil	5
24	057052-050	Bolt, M12 x 50 mm 10.9	8
25	505087-012	Hardened washer, M12	16
26	056064-012	Nyloc nut, M12	8

Table 6-6: SL30SL - 505503-000

ITEM	PART	DESCRIPTION	QTY
1	064100-011	Deck weldment	1
2	510502-000	Ladder weldment	1
3	064111-001	Pedestal weldment	1
4	026554-002	Rivet (main deck)	24
5			
6	064695-000	Kick plate, side	4
7	064697-000	Guardrail, side	4
8	064702-002	Guardrail, end left hand side	1
9	064702-001	Guardrail, end right hand side	1
10	067764-001	Kick plate, gate	1
11	067883-000	Gate weldment	1
12	067712-000	Gate pivot tube	1
13	003570-005	Plunger assembly	1
14	062642-026	Bushing, gate pivot	2
15	066526-004	Gate spring	1
16	064688-001	Pivot bracket RH	2
17	064688-002	Pivot bracket LH	2
18	064447-000	Skirt plate (rubber skirt)	1
19	064448-000	Rubber skirt	1
20	067695-000	Spacer, guardrail	6
21	064046-000	Rail mounting bracket	2
22	010076-000	Manual box (Black plastic)	1
23			
24	057052-050	Bolt, M12 x 50 mm 10.9	8
25	505087-012	Hardened washer, M12	16
26	056064-012	Nyloc nut, M12	8

Table 6-7: SL26SL - 505603-000

ILLUSTRATED PARTS LIST

PLATFORM ASSEMBLY

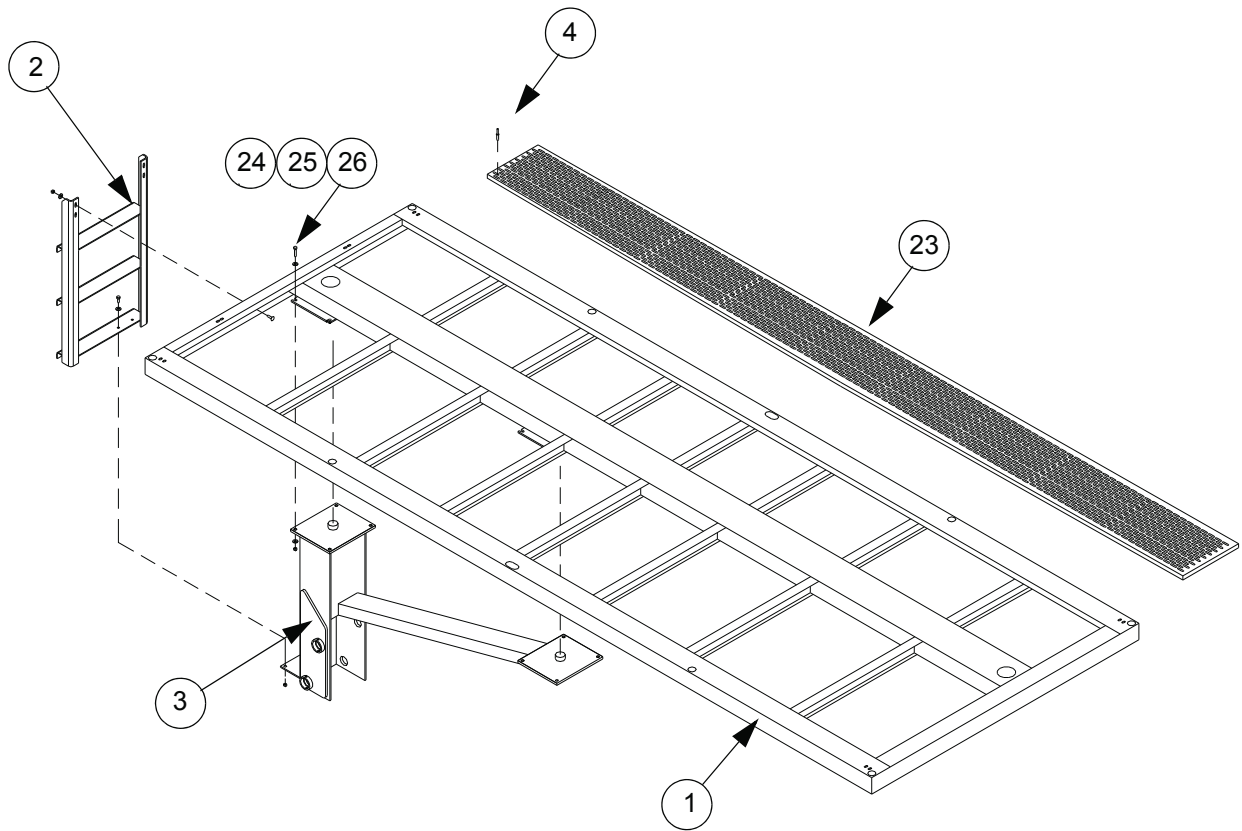

Figure 6-4: Platform assembly of SL26/30SL

PLATFORM ASSEMBLY

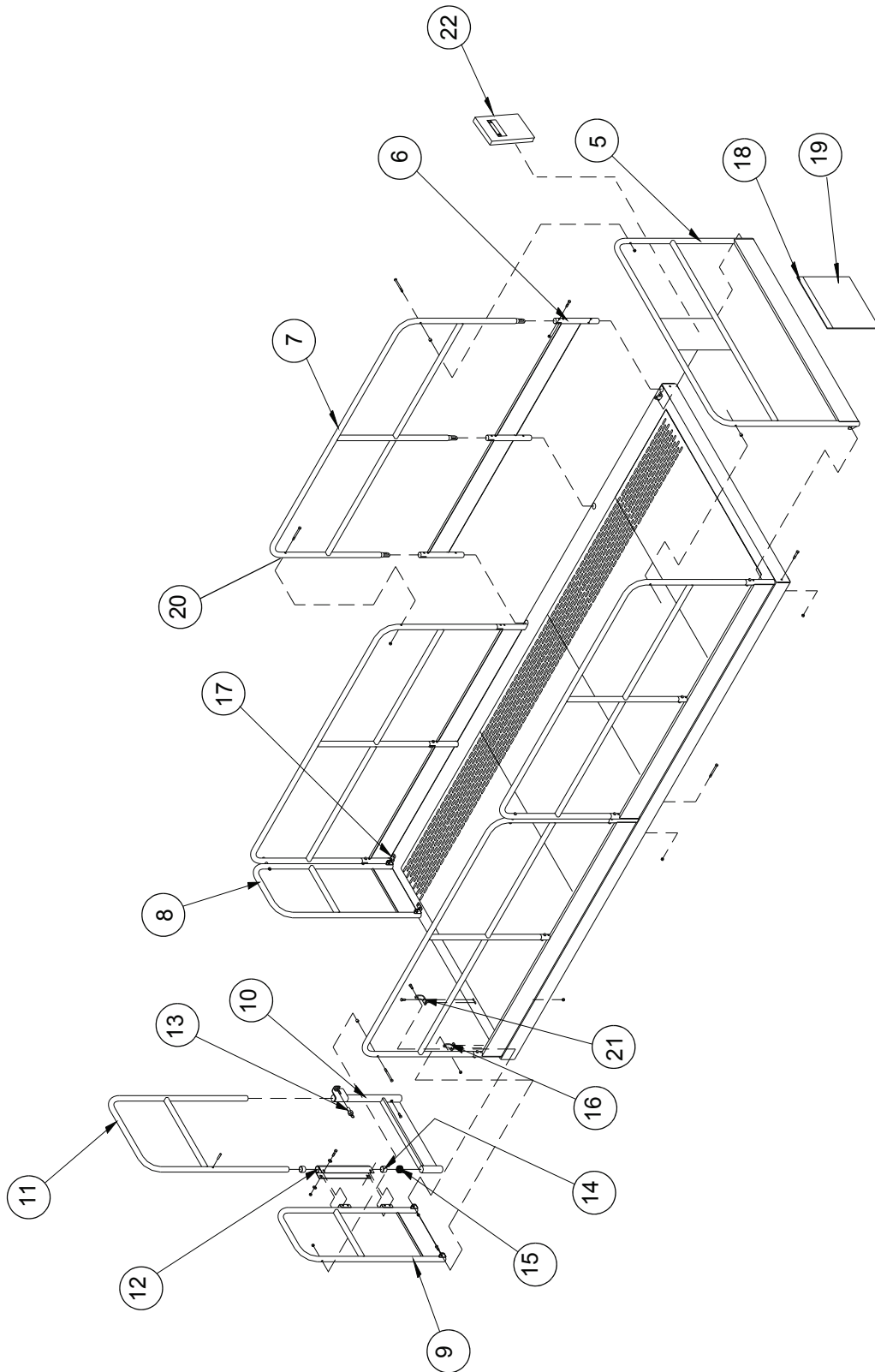

Figure 6-5: Platform assembly of SL26/30SL

ILLUSTRATED PARTS LIST

PLATFORM ASSEMBLY - SLIDE OUT SECTION

ITEM	PART	DESCRIPTION	QTY
1	064785-000	Side rail	2
2			
3	064778-000	Front rail	1
4	064763-000	Deck weldment	1
5	064761-000	Floor (Aluminium)	1
6	063727-000	Block	4
7	064233-000	Wheel (narrow)	4
8	064234-000	Wheel (wide)	2
9	064235-000	Washer	4
10	064776-000	Tube, rail support	2
11	064425-000	Slide bracket	4
12	063990-003	Axle	2
13	064249-000	Bushing (spanner)	2
14	064256-000	Bearing strip	1
15	064795-000	Gusset plate	2
16	064267-000	Bumper pad	4
17	003570-001	Retaining pin assembly	2
18	064774-000	Roller bracket	2
19	064769-001	Right handle	1
20	064769-002	Left handle	1
21	064773-000	Handle bracket	2
22	026553-008	Pop rivet - 3/16 diameter 1/2 - 5/8 grip	12
23	026553-002	Pop rivet - 3/16 diameter 1/8 - 1/4 grip	30
24	011240-004	Flat washer 1/4 standard	22

Table 6-8: SL26SL - 064617-002

ITEM	PART	DESCRIPTION	QTY
25	064240-001	Bushing	2
26	011254-018	Screw - Cap 3/8 - 16 x 2 1/4	4
27	011254-032	Screw - CAP 3/8 - 16 x 4	2
28	011254-010	Screw - CAP 3/8 - 16 x 1 1/4	10
29	067685-000	Spacer	2
30	011248-004	Locknut - 1/4 - 20	22
31	011252-014	Screw - 1/4 - 20 UNC hex hd x 1 3/4	10
32	011248-006	Locknut - 3/8 - 16	26
33	011240-006	Flat washer 3/8 standard	12
34	064775-000	Front angle	2
35			
36			
37	011240-002	Washer #8	6
38	064247-000	Guide slide	3
39	011254-020	Screw - cap 3/8 - 16 x 2 1/2	6
40	011252-016	Screw - cap 1/4 - 20 x 2	4
41	011252-006	screw - cap 1/4 - 20 hex hd x 3/4	2
42	066550-006	Decal - danger	1
43	066551-003	Decal - danger	1
44			
45	011254-008	Screw - 3/8 - 16 hex hd x 1	4
46	064688-001	Bracket - toe board pivot right hand	1
47	064688-002	Bracket - toe board pivot left hand	1
48	101251-001	Decal - danger tip over	1

PLATFORM ASSEMBLY - SLIDE OUT SECTION

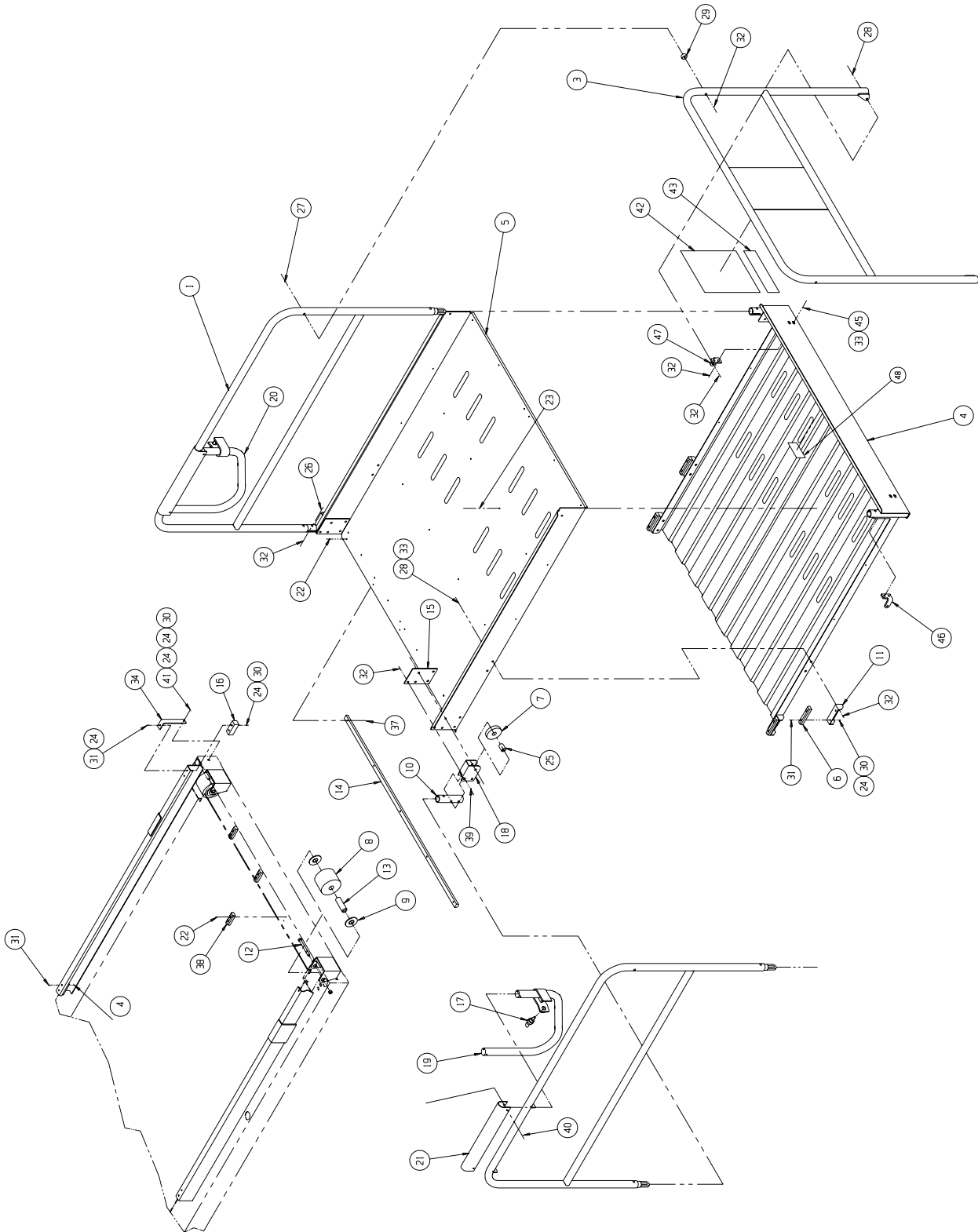

Figure 6-6: Platform assembly (slide out section) of SL26SL

ILLUSTRATED PARTS LIST

ENGINE ASSEMBLY - KUBOTA D902

ITEM	PART	DESCRIPTION	QTY
1	304-0174	Solenoid	1
2	3602-08	Metric hex nut	3
3	3603-06	Plain washer	10
4	3603-08	Plain washer	11
5	3603-10	Plain washer	23
6	3605-08	Spring washer	4
7	056021-008	M8 Spring washer	3
8	3610-06020	Metric bolt	5
9	3610-08020	Metric bolt	1
10	3610-08030	Metric bolt	2
11	3610-08040	Metric bolt	3
12	3610-10025	Metric bolt	8
13	3611-06	Metric nyloc nut	5
14	3611-08	Metric nyloc nut	2
15	3611-10	Metric nyloc nut	8
16	3617-10020	Metric bolt	7
17	3617-10025	Metric bolt	5
18	13986	Throttle solenoid bracket - D902	1
19	12944	Engine mount feet, SRxx70 D902	2
20	058492-025	M8 x 25 bolt	3
21	13023	Throttle lever - D902	1
22	14004	Kubota D902 engine assembly	1
23	13904	Exhaust - SRxx70 D902	1
25	13095	Fuel filter bracket - Kubota D902	1
27	13164	Cable tie mount - M10	4
29	514502-000	Pump - SAE - A, 9 spline 14cc	1
30	14020	Muffler support bracket	1
31	13905	Saddle clamp	1
32	60017-007	1" x 3/8 UNC bolt	3
33	60017-010	1" x 3/8 UNC bolt	2
34	60021-008	1/4" NF hex nut	1
35	60030-049	3/8" plain washer	2
36	512968-000	Hyd fitting - straight ORFS (16) - SAE (16)	1
37	512969-000	Hyd fitting - straight ORFS (08) - SAE (10)	1
38	2650001	Swivel inline	1
39	2690004	Rod end	1
40	7630208	Engine mount	4
41	13987	Coupling - KEA bell housing kit	1

Table 6-9: SL26/30SL - 14004

ENGINE ASSEMBLY - KUBOTA D902

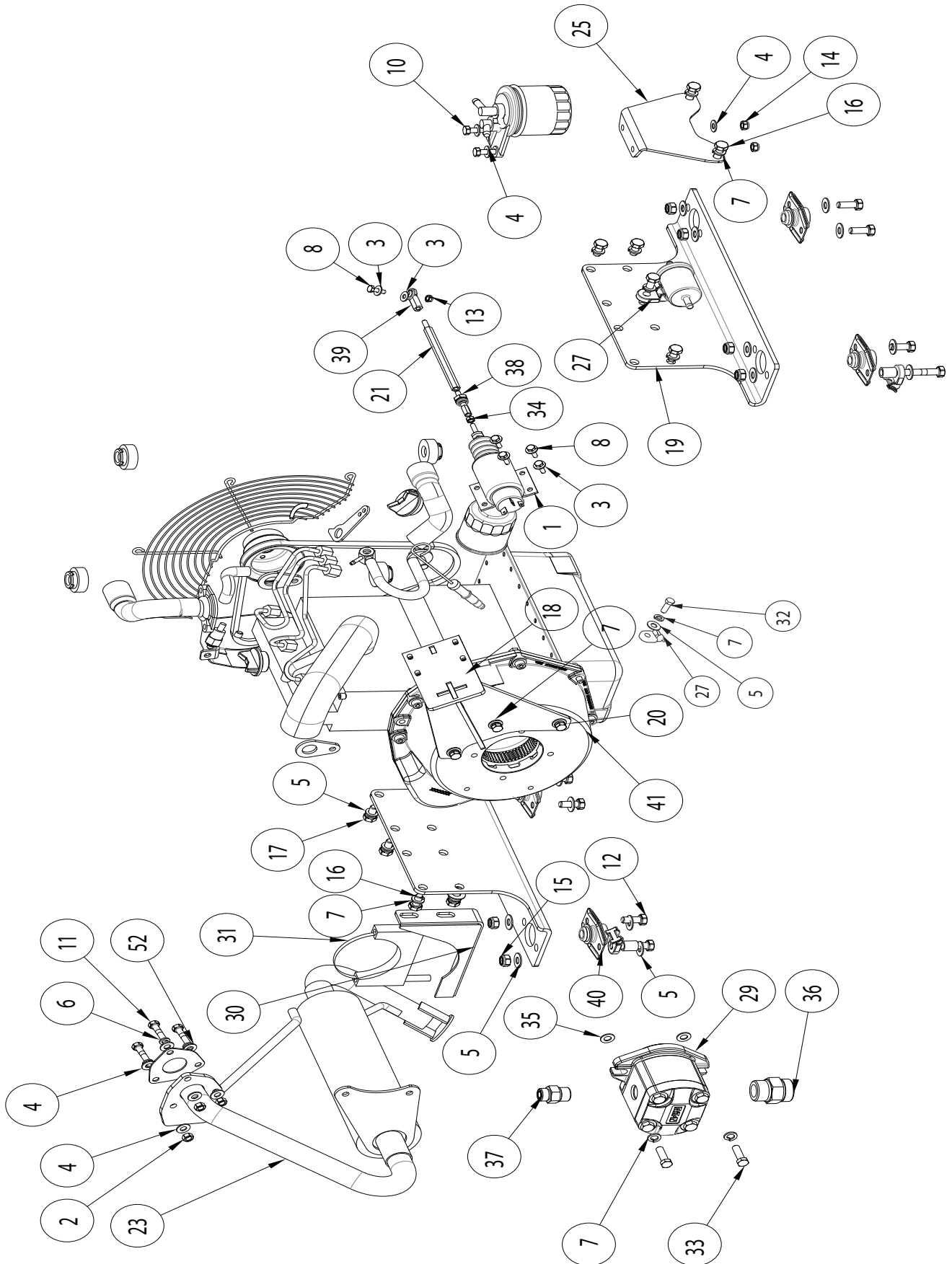

Figure 6-7: Engine assembly of SL26/30SL

ILLUSTRATED PARTS LIST

ENGINE CABINET ASSEMBLY

Key	Meaning
***	Part of engine kit

ITEM	PART	DESCRIPTION	QTY
1	1650-010	Relay	4
2	514612-000	Plugin relay base	4
3	3602-06	Metric hex nut	1
4	3603-04	Plain washer	2
5	3603-05	Plain washer	2
6	3603-06	Plain washer	18
7	3603-08	Plain washer	26
8	3603-10	Plain washer	3
9	3604-04035	Pan head screw M4 x 35	2
10	3604-05012	Pan head screw M5 x 12	2
11	3605-08	Spring washer	2
12	3610-06016	Metric bolt	5
13	3610-06020	Metric bolt	2
14	3610-06025	Metric bolt	1
15	3610-08020	Metric bolt	4
16	3610-08030	Metric bolt	8
17	3610-08100	Metric bolt	2
18	3610-10050	Metric bolt	3
19	3611-04	Metric nyloc nut	2
20	3611-05	Metric nyloc nut	2
21	3611-06	Metric nyloc nut	8
22	3611-08	Metric nyloc nut	12
23	3611-10	Metric nyloc nut	3
24	13869-01	LH hinge	2

ITEM	PART	DESCRIPTION	QTY
25	13869-02	RH hinge	2
26	11679	LH door weld small	1
27	11680	RH door weld large	1
28	12716-13	Top plate engine + control cabinets	1
29	12638	Engine cabinet - Tank side	1
30	12938-1	Cabinet end - radiator vent	1
31	13086-03	Radiator overflow bottle	1
32	13086-04	Air filter assembly	1
33	13086-05	Air filter bracket	1
34	13086-06	Overflow attachment bracket	1
35	13098	Air filter support	2
36	13099-1	Radiator mount - SRxx70 D902	2
37	13106-2A	Fuel tank assembly - SR	1
38	13806	Fuse block - blade x 6	1
39	65004-008	Rubber Grommet	1
40	5560179	Flat washer - special	3
41	8342416	Latch - Adjustable trigger	1
42	***	Radiator	1
43	***	Isolator mount - Kubota	4
44	PCA015	Rubber channel section	1

Table 6-10: SL26/30SL - Kubota D902

ENGINE CABINET ASSEMBLY

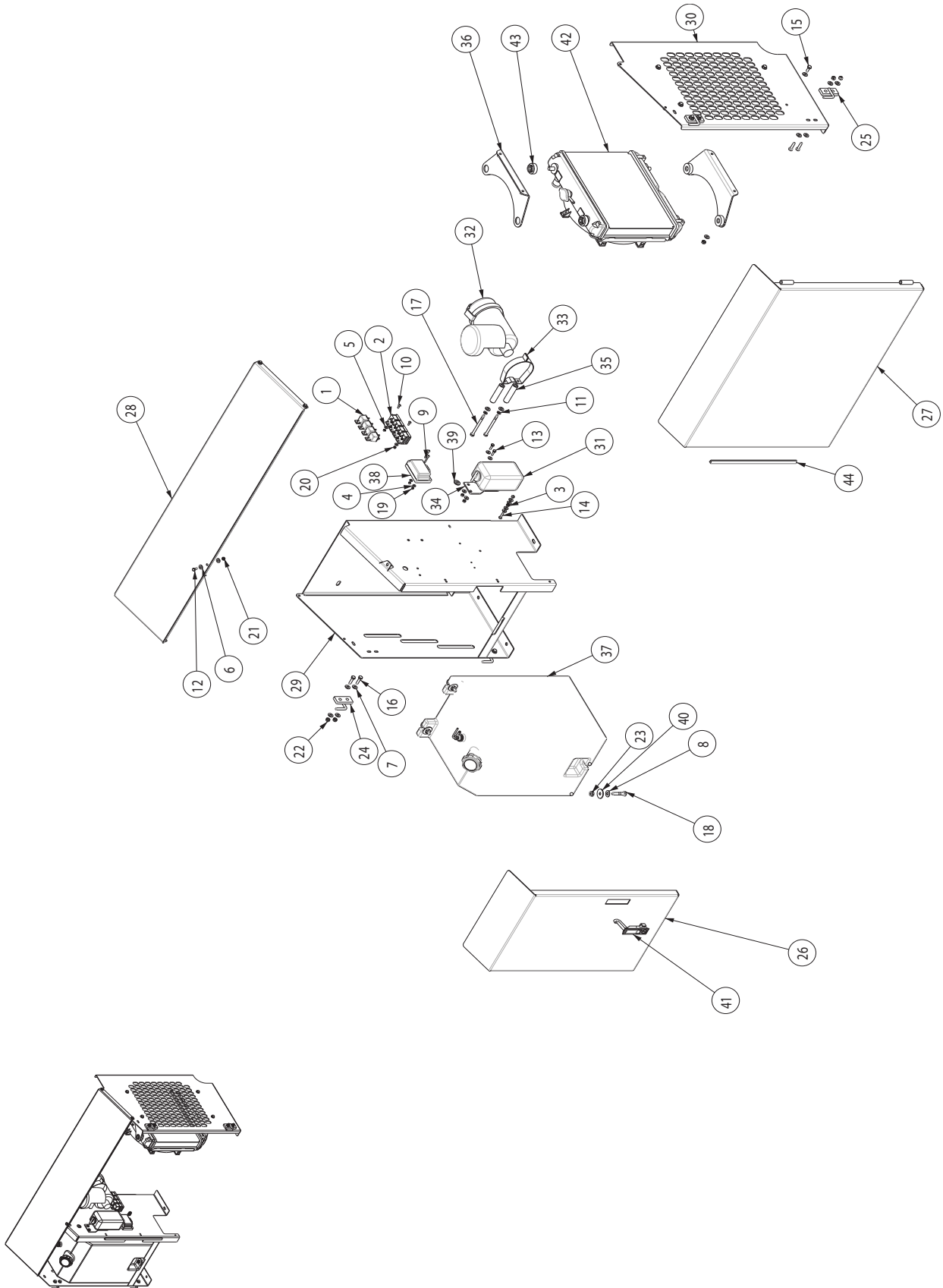

Figure 6-8: Engine cabinet assembly of SL26/30SL

ILLUSTRATED PARTS LIST

CONTROL MODULE ASSEMBLY

ITEM	PART	DESCRIPTION	QTY
1	302-0049	Switch, battery disconnect	1
2	514487-000	LCB CE	1
	514487-001	LCB ANSI	1
3	510505-000	Cover, hydraulic hoses	1
5	510588-005	M5, plain washer	6
6	510588-006	M6, plain washer	8
7	510588-008	M8, plain washer	10
8	510588-010	M10, plain washer	3
9	510593-012	Pan head screw, M5 x 12 mm	2
10	13-2367	Manifold tank line drain	1
11	510567-025	CSK socket head screw, M6 x 25 mm	1
12	058490-025	Bolt, M5 x 25 mm	4
13	058491-016	Bolt, M6 x 16 mm	5
14	058491-020	Bolt, M6 x 20 mm	2
16	510477-000	Stand, manifold mounting	8
17	058492-025	Bolt, M8 x 25 mm	8
18	056060-050	Bolt, M10 x 50 mm	3
19	PCA015	Rubber channel section	1
20	056066-005	Nut, M5 nylock	6
21	056066-006	Nut, M6 nylock	8
22	056066-008	Nut, M8 nylock	8
23	056064-010	Nut, M10 nylock	3
24	3618-26	Hose clamp, 26 - 28 mm	1
25	3618-32	Hose clamp, 34 - 37 mm	1

ITEM	PART	DESCRIPTION	QTY
26	12716-13	Top plate control cabinet	1
27	12716-14	Cabinet support	1
28	8342416	Latch, adjustable trigger	1
29	3040269	Rubber boot cable end	4
30	300840	Lock out lever assembly	1
31	502197-000	M8 x 300 hook bolt	2
32	064040-000	Angle battery hold down	1
33	11470	Left hand hinge	2
34	11470-1	Right hand hinge	2
35	11558	Hydraulic oil tank assembly	1
36	062299-002	Battery, 12 V	1
37	11679	Left hand door weld, small	1
38	11680	Right hand door weld, large	1
40	514721-000	Manifold drive control	1
41	514720-000	Manifold movement control	1
42	514722-000	Control cabinet weld	1
43	5560179	Flat washer, special	3
44	058492-020	Bolt, M8 x 20 mm	2
45	056021-008	M8, spring washer	2
46	508078-001	Filter assembly	1
	508078-000	Filter	1
	508078-002	Filter head	1
47	503789-002	Emergency down cable	1

Table 6-11: SL26/30SL - 505505-000

ILLUSTRATED PARTS LIST

HYDRAULIC VALVE BLOCK MOVEMENT

LOCATION	PART	DESCRIPTION	PORT	QTY
1	510740-000	Cartridge	SV5	1
2	510741-000	Cartridge	SV 1, 2, 3	3
3	510742-000	Cartridge	SV4	1
4	510743-000	Valve	SPI	1
5	510744-000	Valve	RV2	1
6	510745-000	Valve	RVI	1
7	510746-000	Valve	RV3	1
8	514868-000	Coil	CLI	7
9	514869-000	Coil	CL2	2
10	510749-000	Plug	PLG3B	1
11	510750-000	Plug	PLG6	2
12	510751-000	Plug	PLG4	1
13	510752-000	Valve	FR2	1
14	510753-000	Valve	FRI	1
15	510754-000	Valve	EPI	1
16	510755-000	Valve	EC I	1
17	510756-000	Cartridge	DC I	1
18	510757-000	Valve	CV 1, 2, 3	3
19	510758-000	Valve	CV4	1
20	510759-000	Block	BLK	1

Table 6-12: SL26/30SL - 514720-000

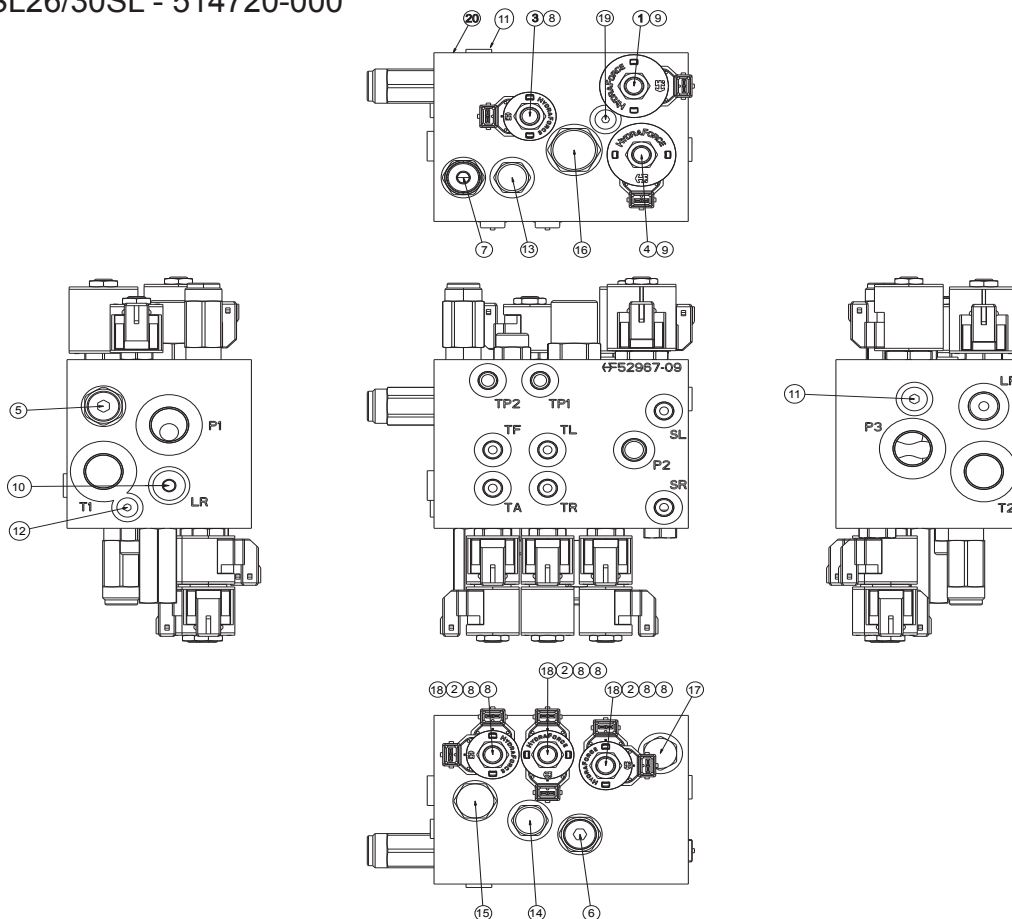

Figure 6-10: Hydraulic valve block movement of SL26/30SL

HYDRAULIC VALVE BLOCK DRIVE

LOCATION	PART	DESCRIPTION	PORT	QTY
1	510760-000	Cartridge	SVDI	1
2	514878-000	Coil	CL3	2
3	510762-000	Head cap screw	CSI	4
4	510763-000	Cartridge	SV4, SV5	2
5	510764-000	Cartridge	SVI3	1
6	510765-000	Cartridge	SV8, SVII	2
7	510766-000	Valve	RV4	1
8	510767-000	Valve	PRI	1
9	510768-000	Valve	PD2	1
10	510769-000	Valve	PDI	1
11	510770-000	Valve	PD3	1
12	510771-000	Valve	PD4	1
13	510772-000	Valve	NVI	1
14	510773-000	Valve	LS2, LS4	2

LOCATION	PART	DESCRIPTION	PORT	QTY
15	510774-000	Orifice plug	ORF1, ORF2, ORF3	3
16	510750-000	Plug	PLG6	5
17	510751-000	Plug	PLG4	12
18	510775-000	Plug	PLG3	1
19	514868-000	Coil	CLI	3
20	514869-000	Coil	CL2	2
21	510778-000	Valve	HPI	1
22	510779-000	Valve	FD2	1
23	510780-000	Valve	FDI, FD3	2
24	510781-000	Valve	FC2	1
25	510782-000	Valve	FC I	1
26	510783-000	Cartridge	CV5, CV6	2
27	510784-000	Valve	PC3	1
28	510785-000	Valve	CBVI, CBV2	2
29	510786-000	Block	BLK	1

Table 6-13: SL26/30SL - 514721-000

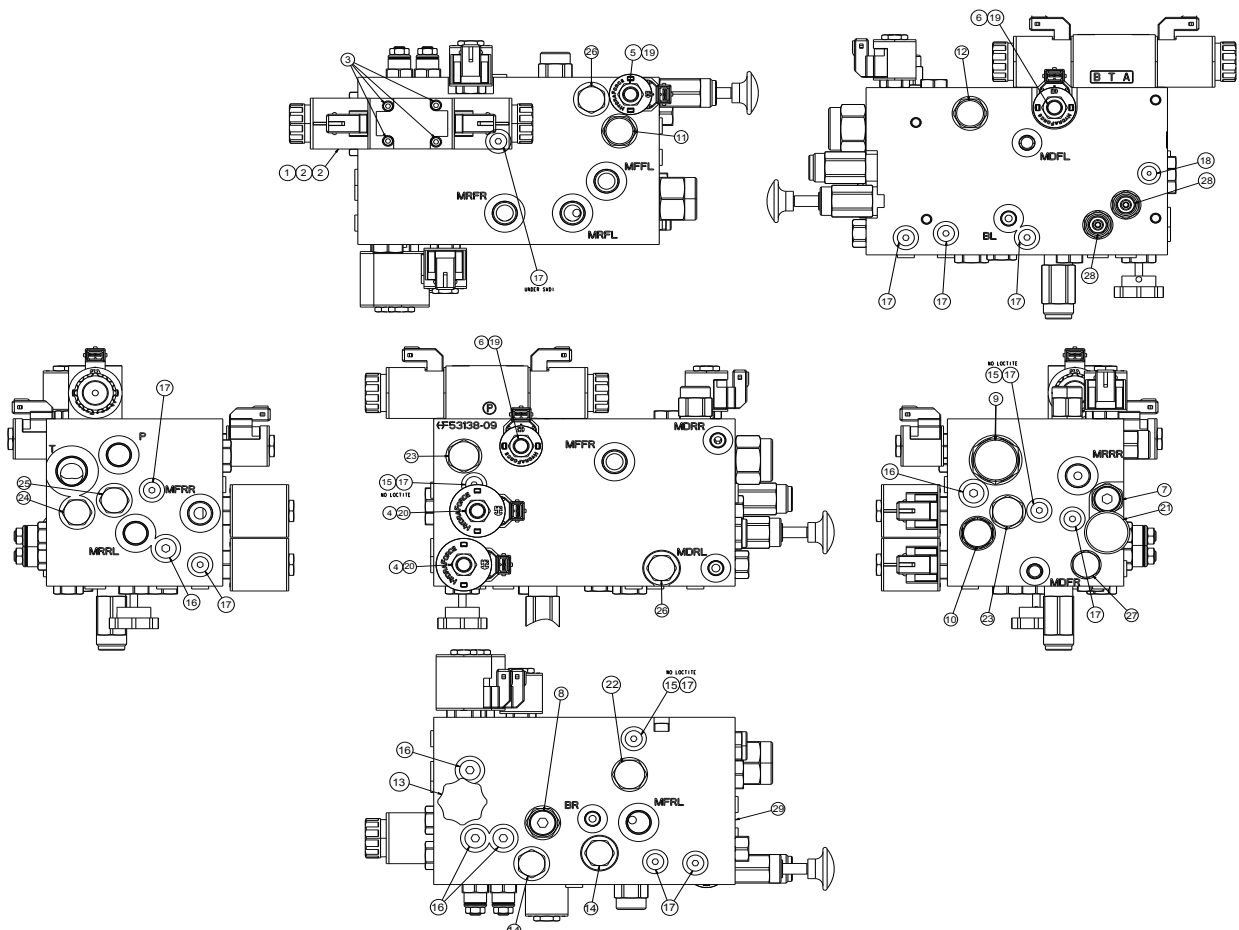

Figure 6-11: Hydraulic valve block drive of SL26/30SL

ILLUSTRATED PARTS LIST

LOWER CONTROL PANEL ASSEMBLY - CE

ITEM	PART	DESCRIPTION	QTY
1	514488-000	LCB weldment	1
2	510521-000	SW TGL SPDT ON - (ON)	1
3	510522-000	SW TGL SPDT (ON) OFF (ON)	1
4	514132-000	Boot	2
5	510542-000	Push button	2
6	3087803	EZcal display	1
7	512543-000	Keyswitch 3 position stayput	1
8	510524-000	SW twist release E/ stop	1
9	514496-000	LCB front panel	1
10	505082-014	Button HD screw M5 x 14 LG	4
11	512366-000	4 way panel plug	2
12	514489-000	Overlay	1
13	514622-000	2 way connector Deutsch DT04-2P-L012	2
14	514626-000	4 way connector, Deutsch DT04-4P-L012	1
15	514624-000	Wedge, Deutsch W2P	2
16	509750-000	Wedge, Deutsch W4P	1

Table 6-14: SL26/30SL - 514487-000

ITEM	PART	DESCRIPTION	QTY
17	514627-000	8 way connector, Deutsch DT04-8PA-L012	1
18	514629-000	Wedge, Deutsch W8P	1
19	509743-000	12 way connector, Deutsch DT04-12PA-L012	4
20	509744-000	Wedge, Deutsch W12P	4
21	13485-05	GP400C ECU SL26&30 software	1
22	510155-000	3 way panel plug	1
23	512817-000	15 way panel plug	4
24	512934-000	LED red 12 V	1
25	502588-000	Alarm, ECCO beeping 6-28 V DC	1
26	13485-03	PG trionics TBM	1
27	509755-000	Mate-N-Lock SCKT contact	4
28	509741-000	Blade fuse holder	1
29	509740-002	10 AMP blade fuse	1
30	100338-013	Crimp pin Deutsch 0460-202-16141	48
31	501251-016	SBHCS M4 x .7 x 16 GR 10.9 black finish	4
32	056069-004	M4 flat washer - grade 8	4
33	056066-004	M4 nylock nut - 8	4

LOWER CONTROL PANEL ASSEMBLY - CE

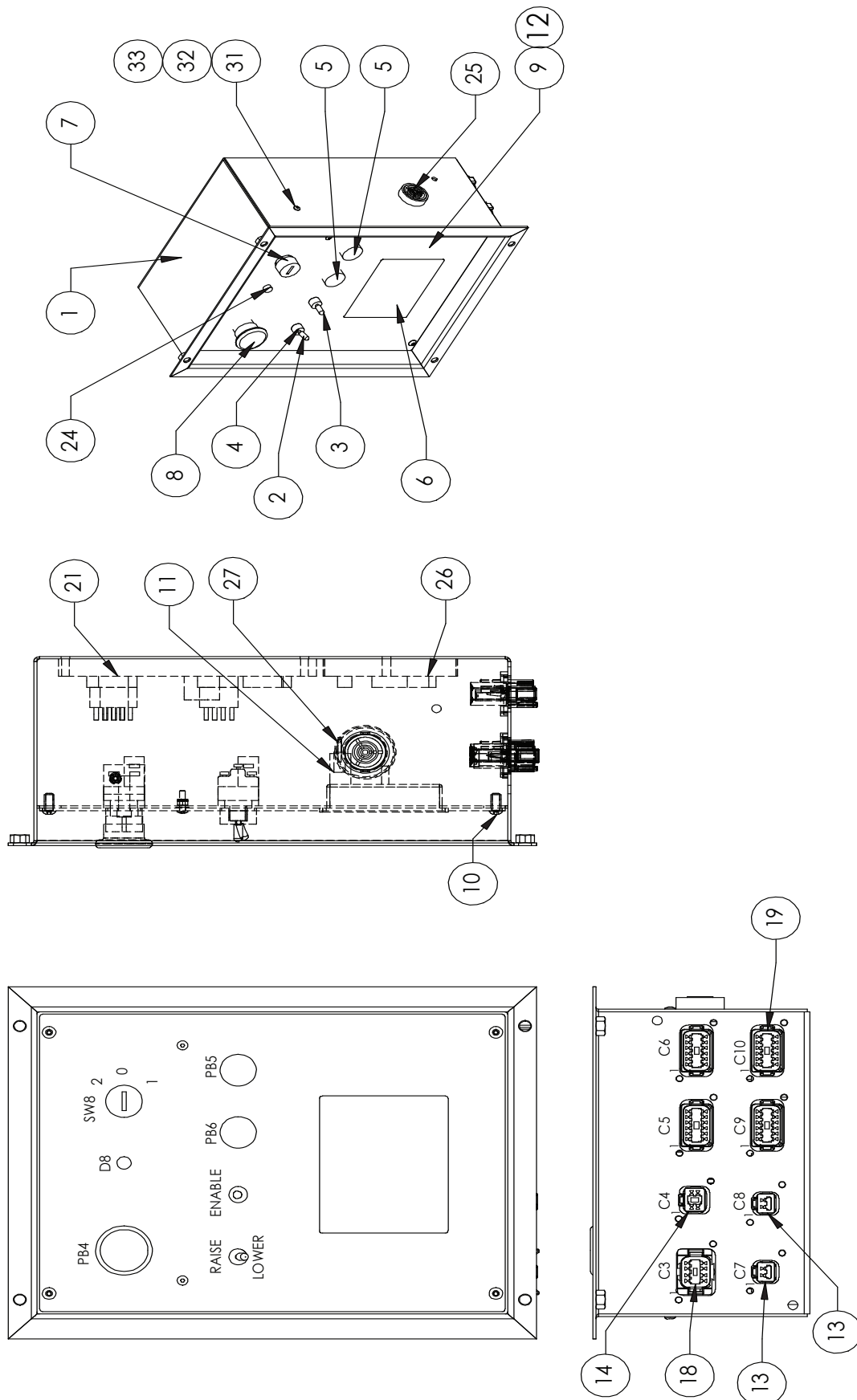

Figure 6-12: Lower control panel assembly of SL26/30SL CE

ILLUSTRATED PARTS LIST

LOWER CONTROL PANEL ASSEMBLY - ANSI

ITEM	PART	DESCRIPTION	QTY
1	514488-000	LCB weldment	1
2	510521-000	SW TGL SPDT ON - (ON)	1
3	510522-000	SW TGL SPDT (ON) OFF (ON)	1
4	514132-000	Boot	2
5	510542-000	Push button	2
6	3087803	EZcal display	1
7	512543-000	Keyswitch 3 position stayput	1
8	510524-000	SW twist release E/ stop	1
9	514496-000	LCB front panel	1
10	505082-014	Button HD screw M5 x 14 LG	4
11	512366-000	4 way panel plug	2
12	514489-000	Overlay	1
13	514622-000	2 way connector Deutsch DT04-2P-L012	2
14	514626-000	4 way connector, Deutsch DT04-4P-L012	1
15	514624-000	Wedge, Deutsch W2P	2
16	509750-000	Wedge, Deutsch W4P	1

Table 6-15: SL26/30SL - 514487-001

ITEM	PART	DESCRIPTION	QTY
17	514627-000	8 way connector, Deutsch DT04-8PA-L012	1
18	514629-000	Wedge, Deutsch W8P	1
19	509743-000	12 way connector, Deutsch DT04-12PA-L012	4
20	509744-000	Wedge, Deutsch W12P	4
21	13485-05	GP400C ECU SL26&30 software	1
22	510155-000	3 way panel plug	1
23	512817-000	15 way panel plug	4
25	502588-000	Alarm, ECCO beeping 6-28 V DC	1
26	13485-03	PG trionics TBM	1
27	509755-000	Mate-N-Lock SCKT contact	4
28	509741-000	Blade fuse holder	1
29	509740-002	10 AMP blade fuse	1
30	100338-013	Crimp pin Deutsch 0460-202-16141	48
31	501251-016	SBHCS M4 x .7 x 16 GR 10.9 black finish	4
32	056069-004	M4 flat washer - grade 8	4
33	056066-004	M4 nylock nut - 8	4

LOWER CONTROL PANEL ASSEMBLY - ANSI

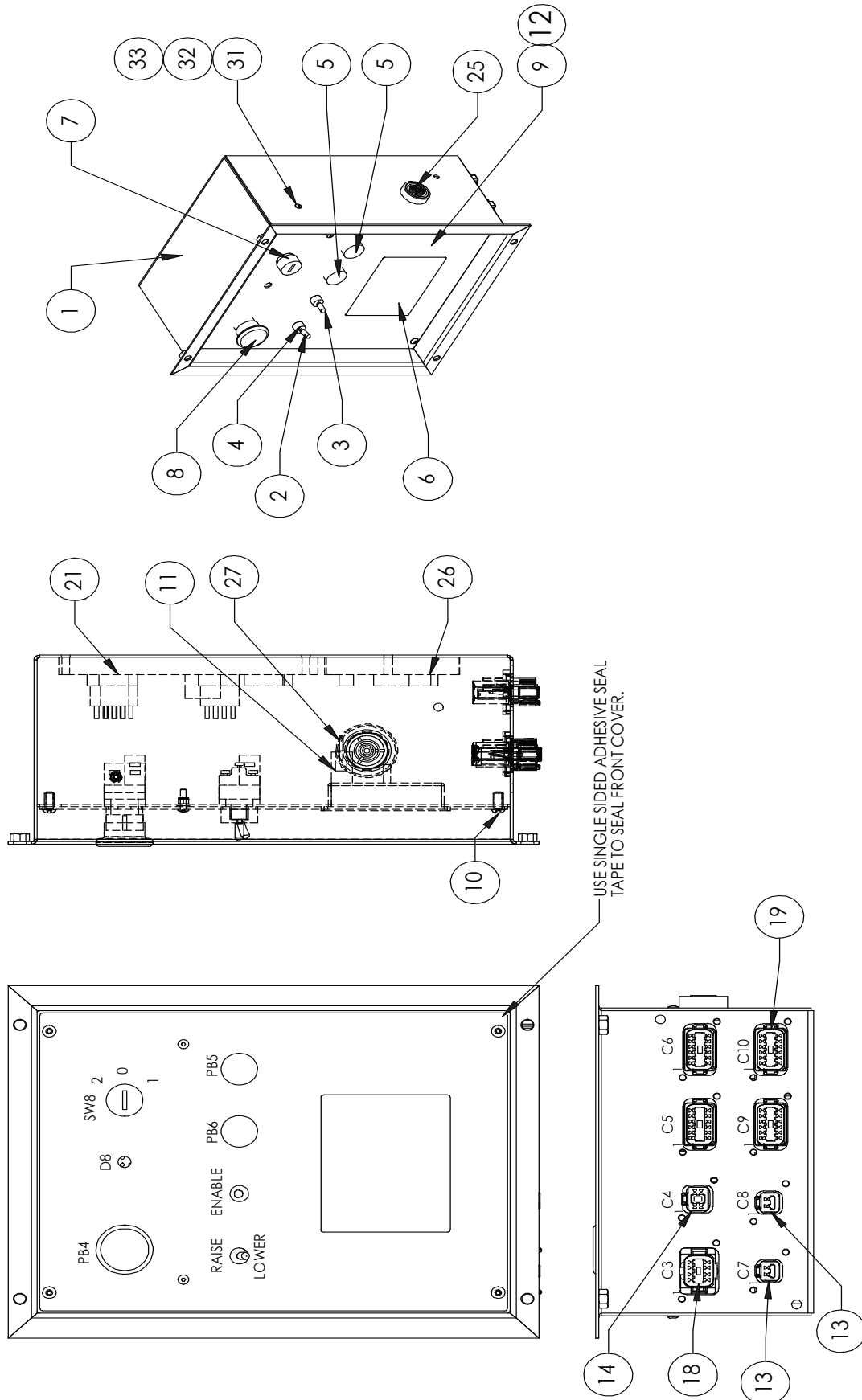

Figure 6-13: Lower control panel assembly of SL26/30SL ANSI

ILLUSTRATED PARTS LIST

UPPER CONTROL PANEL ASSEMBLY - CE

ITEM	PART	DESCRIPTION	QTY
1	514484-000	A38 lower control panel	1
2	510471-000	Joystick	1
3	512934-000	LED red 12 V	3
4	512935-000	LED green 12 V	4
5	510542-000	Push button	2
6	510524-000	SW twist release E/ stop	1
7	514132-000	Boot	5
8	510521-000	SW TGL SPDT ON - (ON)	5
9	514491-000	Contact base 1 N/O 1 N/C	1
10	514490-000	Switch head 3-way stayput/spring to centre	1
11	514485-000	SL UCB enclosure	1
12	056066-005	M5 Nylock nut - 8	4
13	056069-005	M5 washer - grade 8	8
14	058501-025	M5 x 25 S.H.C.S. - GR 12.9	4
15	058501-016	M5 x 16 S.H.C.S. - GR 12.9	4

Table 6-16: SL26/30SL - 514483-000

ITEM	PART	DESCRIPTION	QTY
16	502588-000	Alarm, ECCO beeping 6 - 28 V DC	1
17	510472-000	Matrix board	1
18	510157-000	12 way panel plug	2
19	510156-000	9 way panel plug	1
20	510154-000	6 way panel plug	1
21	058500-025	M4 x 25 SHCS - 12.9	2
22	056066-004	M4 nylock nut - 8	2
23	056069-004	M4 flat washer - grade 8	2
24	509755-000	Mate-N-lock socket contact	26
25	514604-000	Lockwasher Deutsch 114021	1
26	514605-000	Locknut Deutsch 114020-90	1
27	3049862	14 way connector Deutsch HD34-18- 14PN	1
28	100338-013	Crimp pin Deutsch 0460-202-16141	7
29	514486-000	Overlay	1
30	514945-000	Joystick harness	1

UPPER CONTROL PANEL ASSEMBLY - CE

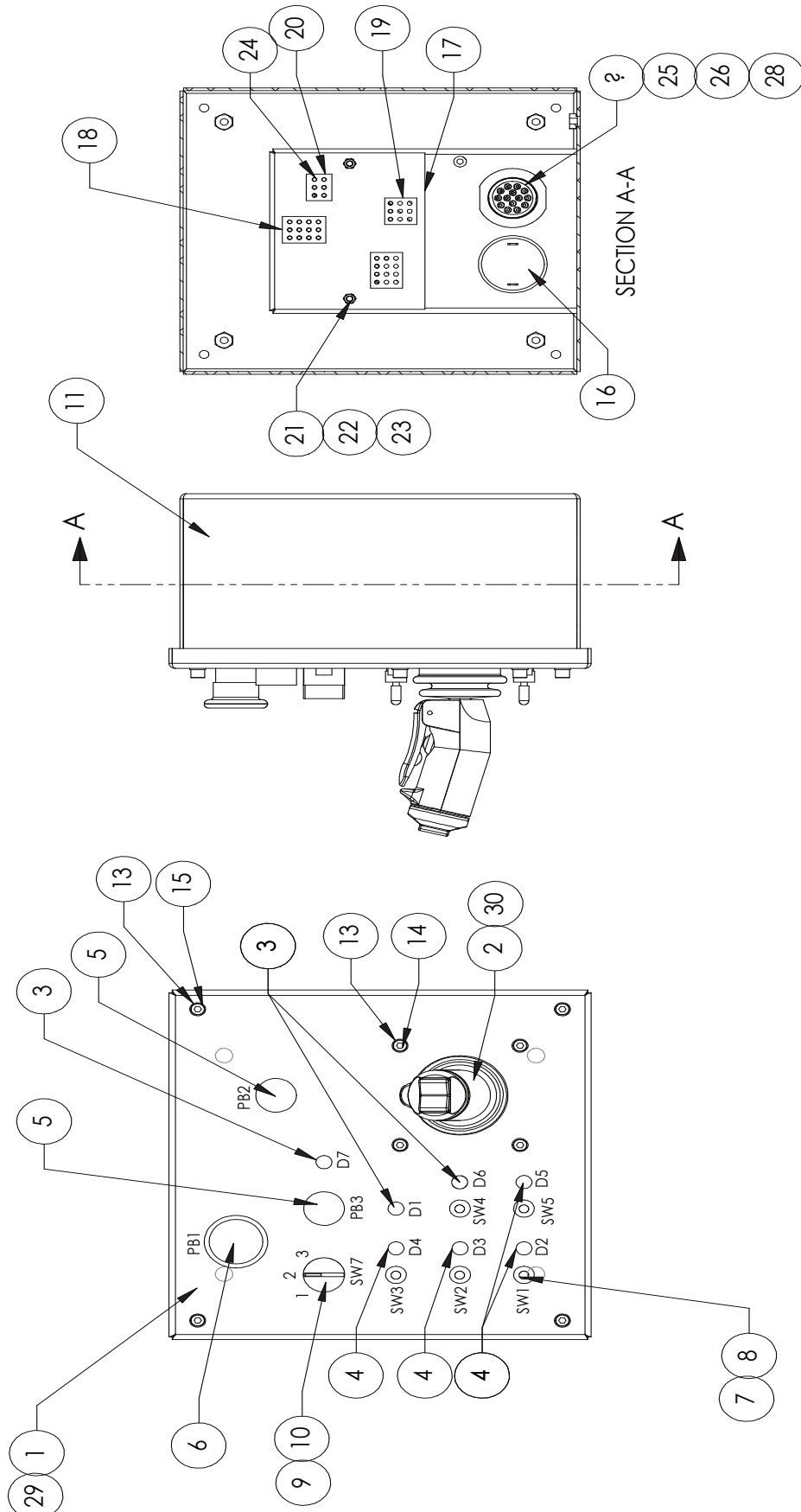

Figure 6-14: Upper control panel assembly of SL26/30SL ANSI

ILLUSTRATED PARTS LIST

UPPER CONTROL PANEL ASSEMBLY - ANSI

ITEM	PART	DESCRIPTION	QTY
1	514484-000	A38 lower control panel	1
2	510471-000	Joystick	1
3	512934-000	LED red 12 V	2
4	512935-000	LED green 12 V	4
5	510542-000	Push button	2
6	510524-000	SW twist release E/ stop	1
7	514132-000	Boot	5
8	510521-000	SW TGL SPDT ON - (ON)	5
9	514491-000	Contact base 1 N/O 1 N/C	1
10	514490-000	Switch head 3-way stayput/spring to centre	1
11	514485-000	SL UCB enclosure	1
12	056066-005	M5 Nylock nut - 8	4
13	056069-005	M5 washer - grade 8	8
14	058501-025	M5 x 25 S.H.C.S. - GR 12.9	4
15	058501-016	M5 x 16 S.H.C.S. - GR 12.9	4

Table 6-17: SL26/30SL - 514483-001

ITEM	PART	DESCRIPTION	QTY
16	502588-000	Alarm, ECCO beeping 6 - 28 V DC	1
17	510472-000	Matrix board	1
18	510157-000	12 way panel plug	2
19	510156-000	9 way panel plug	1
20	510154-000	6 way panel plug	1
21	058500-025	M4 x 25 SHCS - 12.9	2
22	056066-004	M4 nylock nut - 8	2
23	056069-004	M4 flat washer - grade 8	2
24	509755-000	Mate-N-lock socket contact	26
25	514604-000	Lockwasher Deutsch 114021	1
26	514605-000	Locknut Deutsch 114020-90	1
27	3049862	14 way connector Deutsch HD34-18- 14PN	1
28	100338-013	Crimp pin Deutsch 0460-202-16141	7
29	514486-000	Overlay	1
30	514945-000	Joystick harness	1

UPPER CONTROL PANEL ASSEMBLY - ANSI

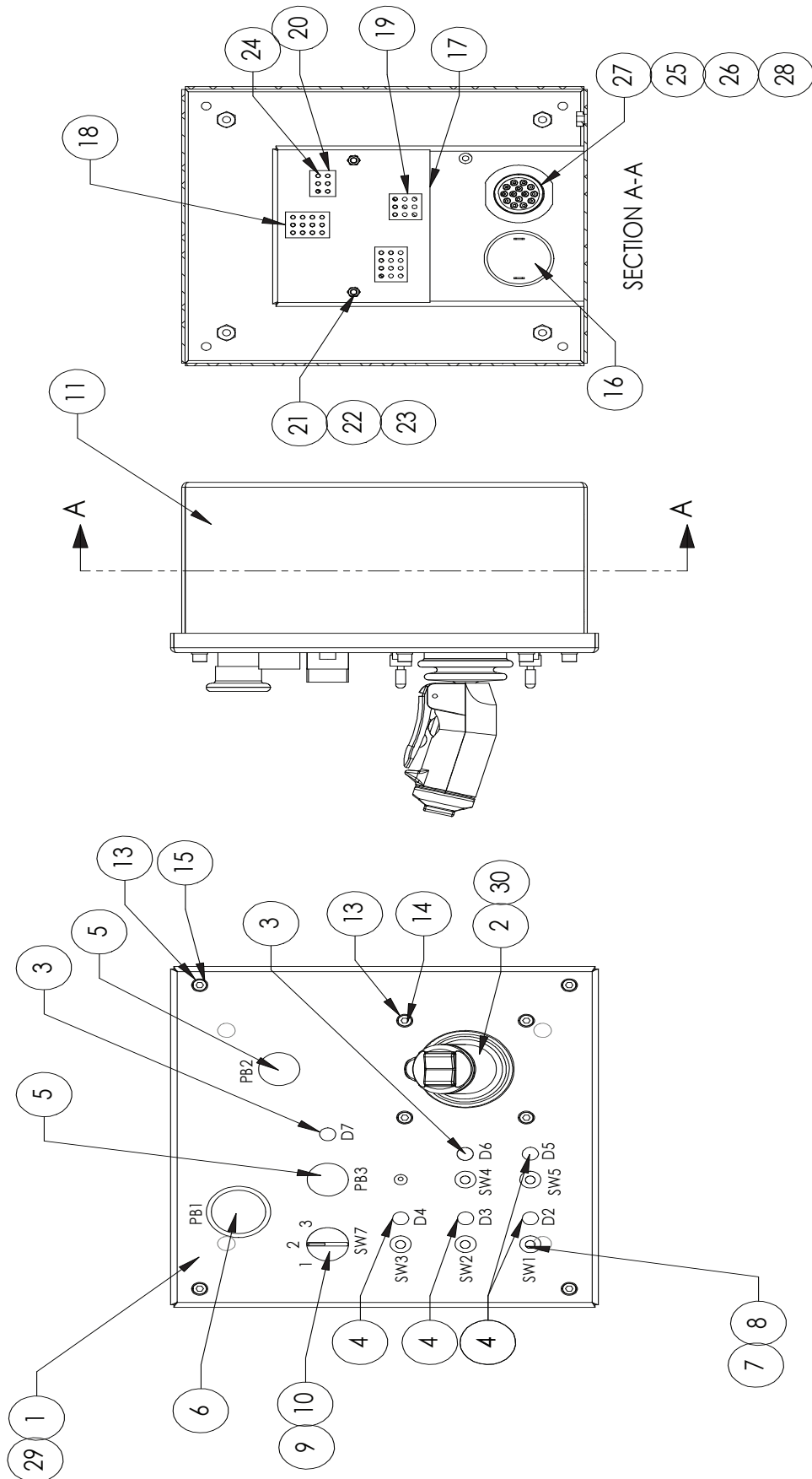

Figure 6-15: Upper control panel assembly of SL26/30SL ANSI

ILLUSTRATED PARTS LIST

UPPER CONTROL PANEL ASSEMBLY - ADDITIONS

ITEM	TOP LEVEL	PART	DESCRIPTION	QTY
1	514521-000	514521-001	UCB mount side plate	1
2		514521-002	UCB mount base	1
3		514521-003	UCB mount fillet	1
4		302544	Pin snapper with lanyard .375 x 2.25	
5		14002	Wrist support	1

Table 6-18: SL26/30SL - 514521-000, 302544, 14002, 13843-03

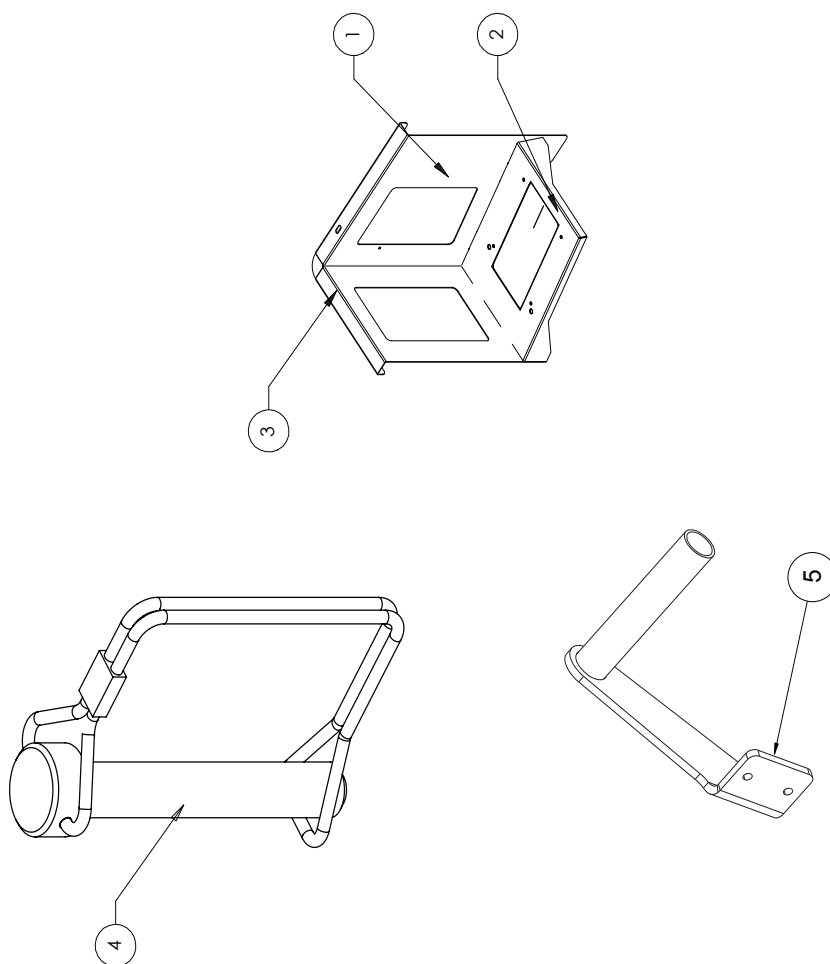

Figure 6-16: Upper control assembly extra's of SL26/30SL

HYDRAULIC OIL TANK ASSEMBLY

ITEM	PART	DESCRIPTION	QTY
1	056069-006	Washer M6	10
2	056069-010	Washer M10	3
3	056060-050	Bolt, M10 x 50	3
4	056066-006	Nut, nylock M6	10
5	056064-010	Nut, nylock M10	3
6	3618-11	Hose clamp, 11 - 25 mm	1
7	3618-26	Hose clamp, 26 - 28 mm	2
8	3618-32	Hose clamp, 34 - 37 mm	1
9	11430-1	Base plate weld	1
10	11430-5	Gasket	1
11	11487	Filter breather	1
12	11558-1	Tank, 13 gallon	1
13	11558-2	Top plate weld, plated	1
14	11558-8	Tank inner hose	1
15	452756	Plug, magnetic	1
16	605246	Strainer, hydraulic tank filter	1
17	605256	cap, vented standard	1
18	5560179	Flat washer, special	3

Table 6-19: SL26/30SL - 11558

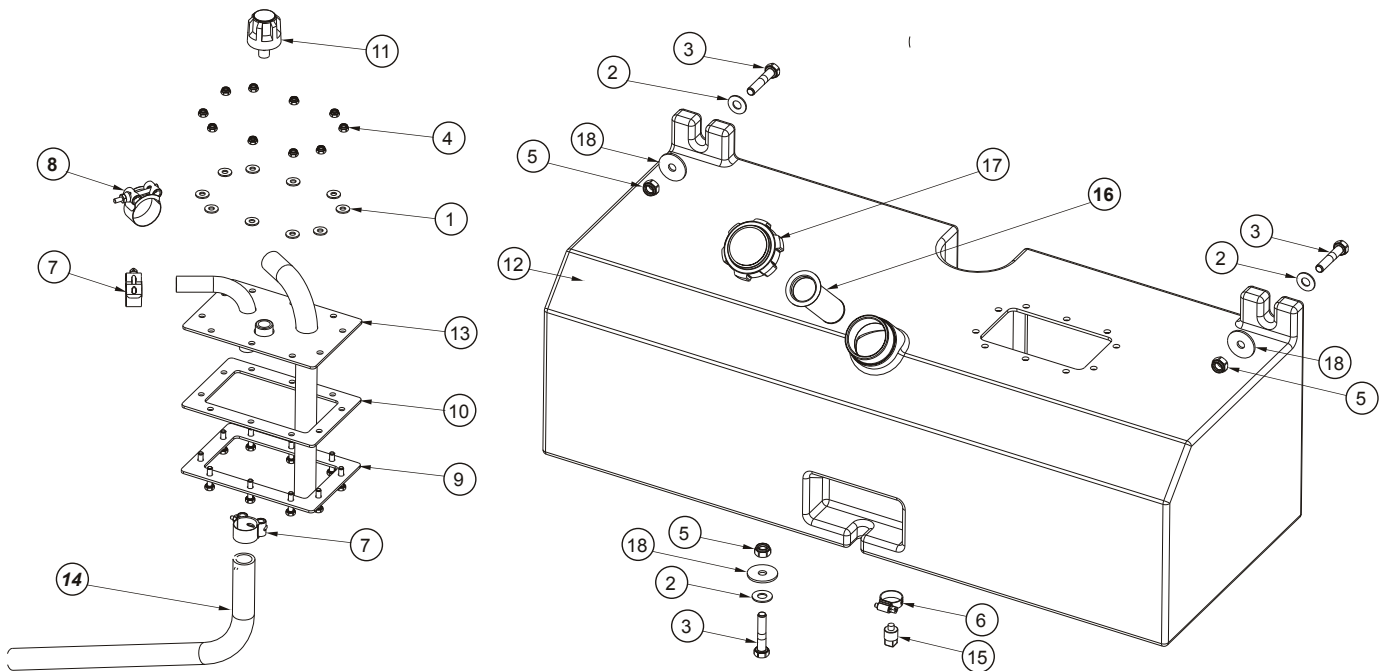

Figure 6-17: Hydraulic oil tank assembly of SL26/30SL

ILLUSTRATED PARTS LIST

FUEL TANK ASSEMBLY - DIESEL

ITEM	PART	DESCRIPTION	QTY
1	3618-11	Hose clamp, 11-12 mm	3
2	13106-1	Fuel tank	1
3	13108-04	Plug, 1/4" NPTM	1
4	13109	Fuel return weld	1
5	605256	Cap, vented	1
6	967309	Male elbow, 5/16" x 1/4", BSPT	1

Table 6-20: SL26/30SL - 13106-2a

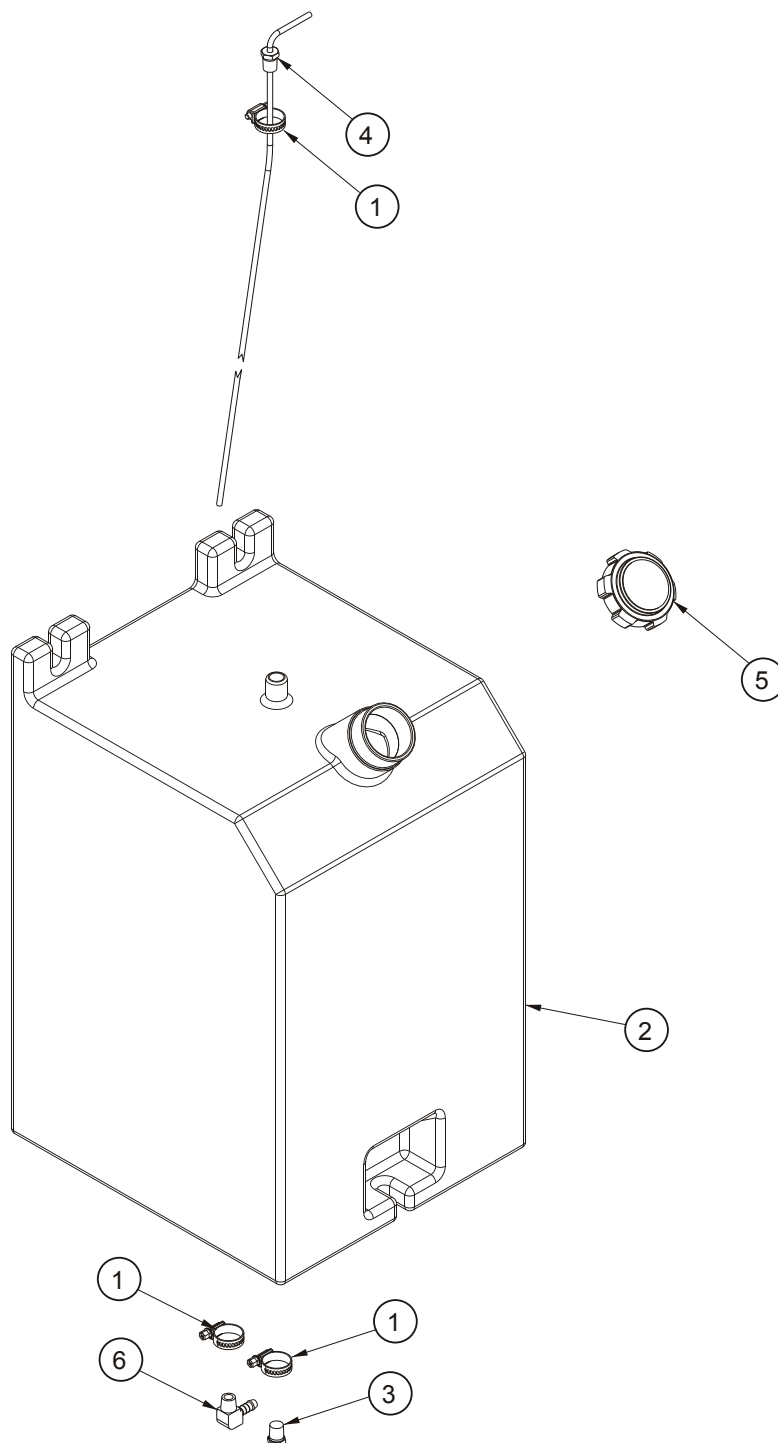

Figure 6-18: Fuel tank assembly of SL26/30SL

HYDRAULIC HOSE ASSEMBLY

ITEM	PART	DESCRIPTION	QTY
1	510380-000	LHF motor drain to BH	1
2	510381-000	LHF BH to return manifold	1
3	510382-000	RHF motor drain to BH	1
4	510383-000	RHF BH to return manifold	1
5	510384-000	LHR motor drain to BH	1
6	510385-000	LHR BH to return manifold	1
7	510386-000	RHR motor drain to BH	1
8	510387-000	RHR BH to return manifold	1
9	510388-000	Lift cylinder to return manifold	1
10	510389-000	Brake port to LHR BH TEE	1
11	510390-000	LHR BH to LH brake	1
12	510391-000	LHR BH TEE to RHR BH	1
13	510392-000	RHR BH to RH brake	1
14	510393-000	Movement manifold to tilt cylinder	4
15	510394-000	Steer cylinder to LHF BH	1
16	510395-000	LHF BH to movement manifold (SL)	1
17	510396-000	Steer cylinder to RHF BH	1
18	510397-000	RHF BH to movement manifold (SR)	1
19	510398-000	Run TEE to axle float	1
20	510399-000	Axle float to tank	1
21	510400-000	Return manifold to tank	1

Table 6-21: SL26/30SL - 510379-000

ITEM	PART	DESCRIPTION	QTY
22	510401-000	Movement manifold to lift cylinder	1
23	510402-000	Pump to movement manifold	1
24	510403-000	Drive manifold to return filter	1
25	510404-000	Drive manifold MFFL to BH	1
26	510405-000	Drive manifold MRFL to BH	1
27	510406-000	Drive manifold MFFR to BH	1
28	510407-000	Drive manifold MRFR to BH	1
29	510408-000	Drive manifold MFRL to BH	1
30	510409-000	Drive manifold MRRL to BH	1
31	510410-000	BH to RL motor	2
32	510411-000	Drive manifold MFRR to BH	1
33	510412-000	Drive manifold MRRR to BH	1
34	510413-000	BH to RR motor	2
35	510414-000	Movement to drive manifold press	1
36	510415-000	Movement to drive manifold return	1
37	510416-000	BH to RHF motor	2
38	510417-000	BH to LHF motor	2
39	510418-000	Return filter to tank	1
40	510419-000	Tank to pump suction	1
41	510826-000	Lift TEE to axle float cylinder	2

ILLUSTRATED PARTS LIST

HYDRAULIC HOSE ASSEMBLY

PART	DESCRIPTION	QTY
	Bonded seal	
058298-000	1/8 bonded seal, self centering	2
057124-000	1/4 bonded seal, self centering	35
057125-000	3/8 bonded seal, self centering	17
057376-000	1/2 bonded seal, self centering	16
057352-000	3/4 bonded seal, self centering	8
	Adaptors and fittings	
057358-000	Adapter male - male, 1/4 BSP	17
057122-000	Adapter male - male, 3/8 BSP	1
057377-000	Adapter male - male, 1/2 BSP	14
058350-000	Adapter male - male, 3/4 BSP	3
509543-000	Adapter male - male, 1/8 BSP - 1/4 BSP	2
057121-000	Adapter male - male, 1/4 BSP - 3/8 BSP	7
057123-000	Adapter male - male, 3/8 BSP - 1/2 BSP	1
503169-000	Adapter male - male, 1/2 BSP - 3/4 BSP	4

Table 6-22: SL26/30SL - 510379-000

PART	DESCRIPTION	QTY
510692-000	Adapter male - male, 3/4 BSP - 1 BSP	1
058707-000	Plug, 3/8 BSP	3
057352-000	Plug, 1/2 BSP	2
510685-000	Plug, 1/4 BSP	4
508307-000	Banjo bolt, 1/4 BSP	5
510686-000	Test point - minimess, 1/4 BSP	2
510687-000	Bulkhead adapter M-M, 1/4 BSP	12
510688-000	Bulkhead adapter M-M, 1/2 BSP	8
510673-000	45 degrees positional elbow M-M, 1/2 BSP	4
510689-000	90 degrees block elbow M-F, 1 BSP	1
510336-000	2.0 mm 50 bar screw in free flow - flow restrictor, 3/8 BSP	1
510690-000	Run TEE 1/4, 1/4 BSP female, BSP male	1
510691-000	Run TEE 1/2, 1/2 BSP female, BSP male	1
510823-000	Run TEE 3/8 male, 3/8 BSP female, 1/4 BSP male branch	1
510824-000	Run TEE 3/4 male, 3/4 BSP female, 1/4 BSP male branch	1

HYDRAULIC HOSE ASSEMBLY

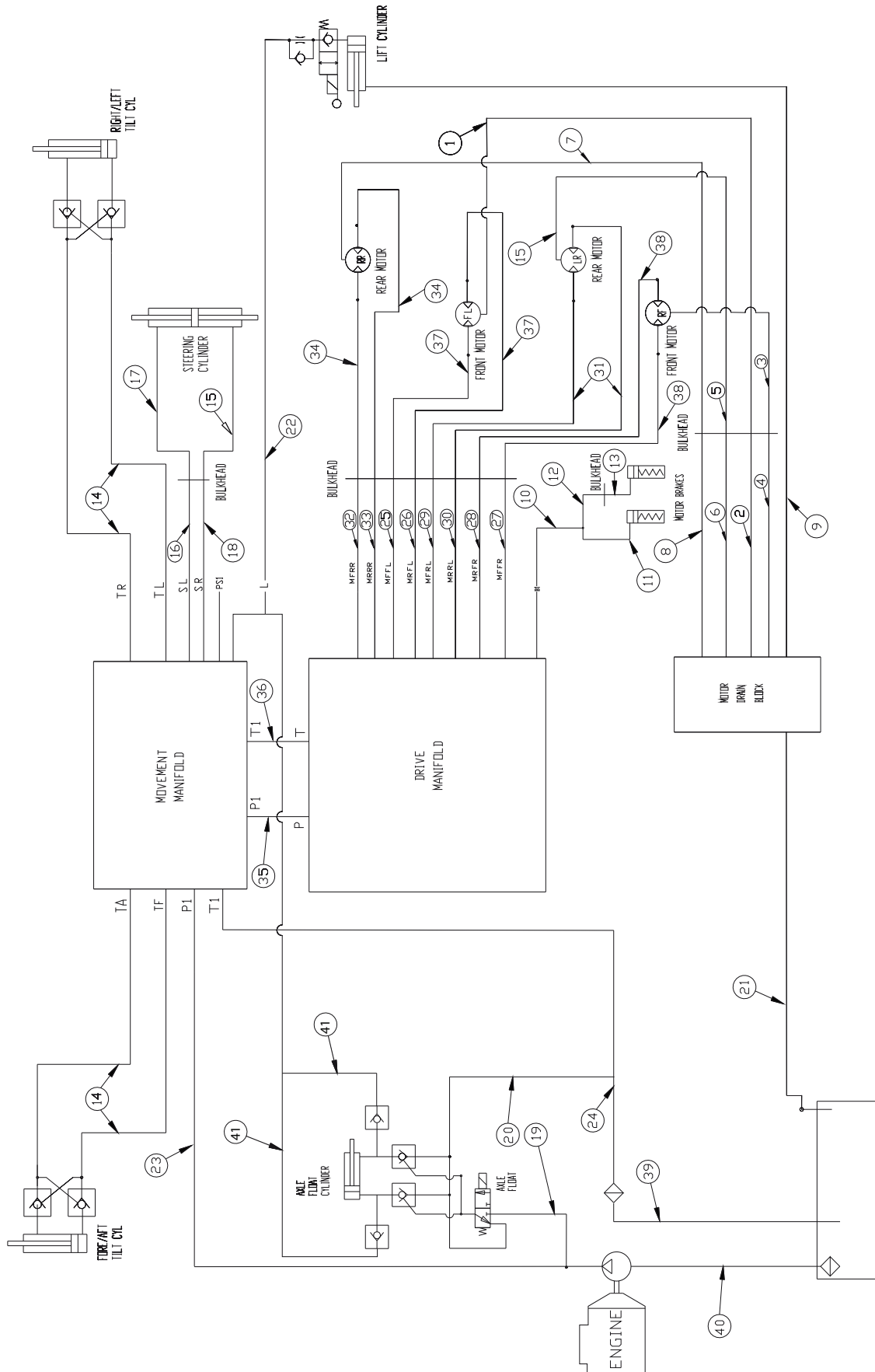

Figure 6-19: Hydraulic hose assembly of SL26/30SL

ILLUSTRATED PARTS LIST

HYDRAULIC CYLINDER ASSEMBLY - MAIN LIFT

ITEM	PART	DESCRIPTION	QTY
1	Contact product support	Cylinder body	1
2	Contact product support	Solenoid valve (EM down) 12V	1
3	Contact product support	Lock nut	1
4	Contact product support	Piston head	1
5	063904-010	Seal kit	1
6	Contact product support	Spacing sleeve	1
7	Contact product support	Cap, body end	1
8	Contact product support	Cylinder rod	1
9	062649-010	Flanged bushing	2
10	058819-000	M6 grease nipple	2
11	Contact product support	Bushing	2

Table 6-23: SL26/30SL - 063904-101

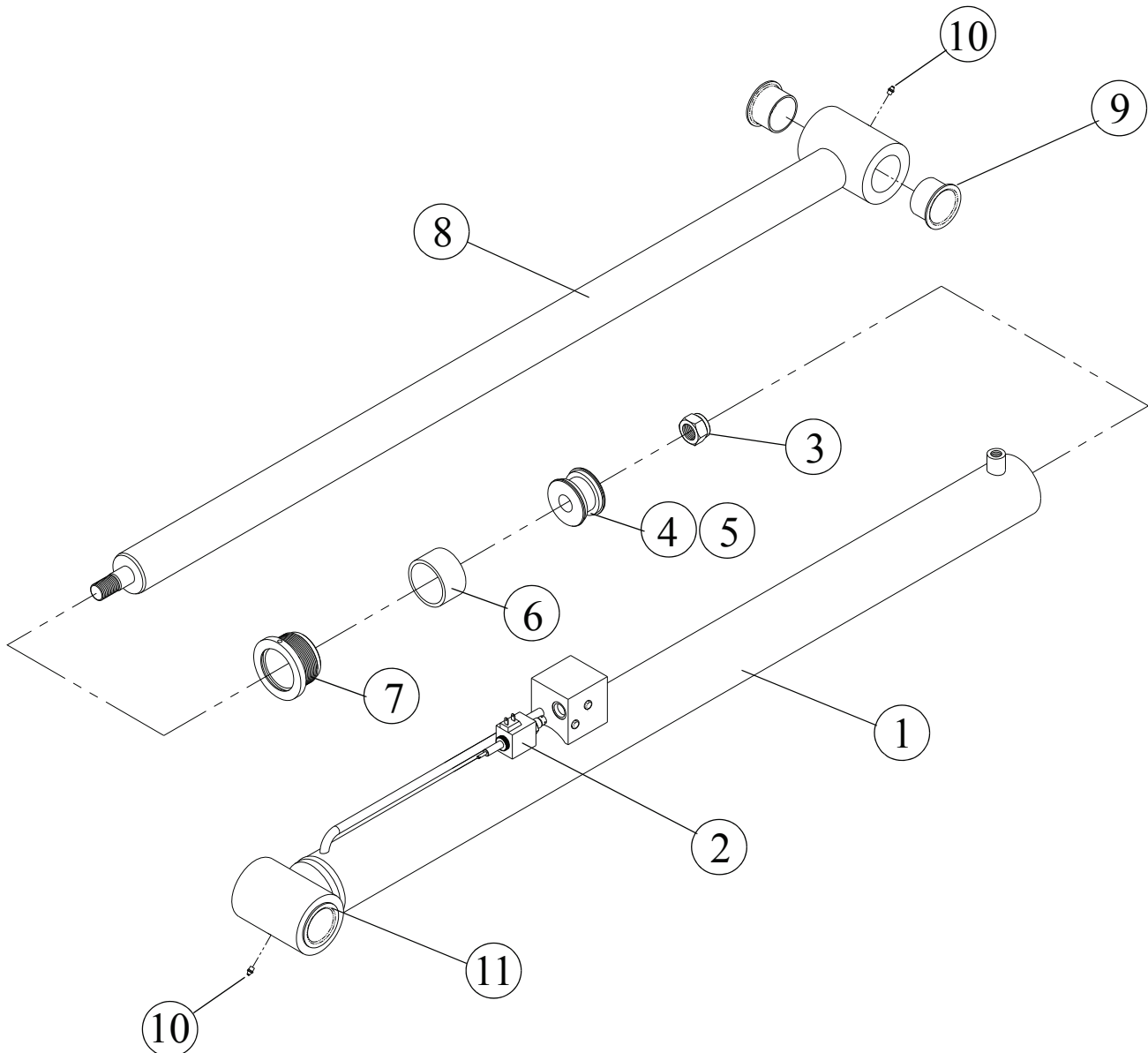

Figure 6-20: Hydraulic cylinder assembly of SL26/30SL

STEER, AXLE FLOAT & TILT CYLINDER

ITEM	PART	DESCRIPTION	QTY
1	063905-010	Seal kit - steer cylinder	1
2	064345-010	Seal kit - tilt cylinder	1
3	064346-010	Seal kit - axle float cylinder	1

Table 6-24: SL26/30SL - Seal kit for steer, tilt & axle float cylinder respectively

ITEM	PART	DESCRIPTION
1	063905-101	Steer cylinder
2	064345-100	Tilt cylinder
3	064346-100	Axle float cylinder

Table 6-25: SL26/30SL - Steer, tilt & axle float cylinder identification number

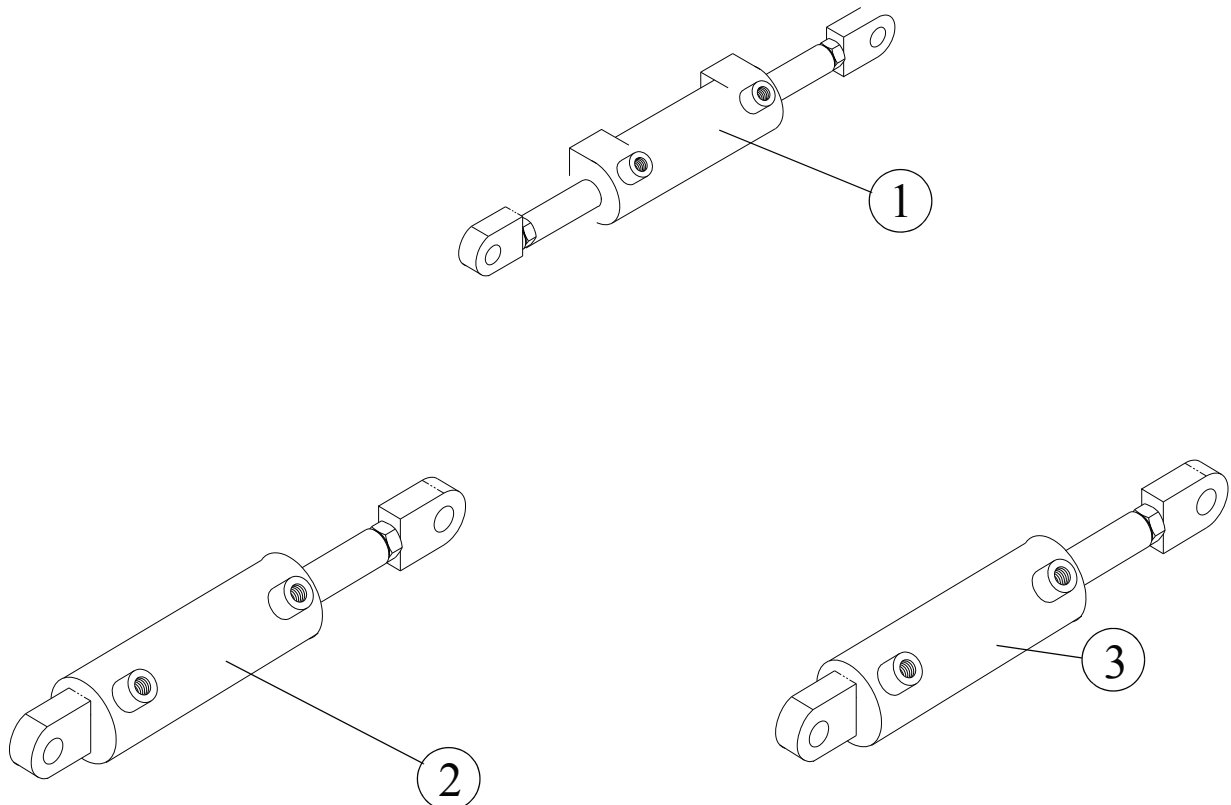

Figure 6-21: Hydraulic cylinder components of SL26/30SL

ILLUSTRATED PARTS LIST

ELECTRICAL ASSEMBLY - PLATFORM CONTROL BOX

PART	DESCRIPTION	QTY
514485-000	Enclosure	1
514484-000	Enclosure lid	1
514486-000	Platform control box overlay	1
510471-000	Joystick	1
512934-000	Red LED	3
512935-000	Green LED	4
510542-000	Black flush push button c/w 1 N/O contact block	2
510524-000	Twist & release E/stop c/w 1 N/C contact block	1
510521-000	Toggle switch, on-(on) IP65	5
514132-000	Boot	5
514491-000	Contact base with 1 N/O & N/C contact blocks	1
514490-000	Rotary switch head 3 position stayput/stayput/return to centre	1
502588-000	Alarm	1
510472-000	Matrix board	1
510157-000	12 - way panel plug	2
510156-000	9 - way panel plug	1
510154-000	6 - way panel plug	1
509755-000	Mate-N-lock socket contact	26
514604-000	Panel lock washer	1
514605-000	Panel locknut	1
100338-013	Crimp pin	7
3049862	14 - way connector	1
510671-000	Cable 1.0 mm CSA	5 m
510645-000	Seal strip	1.1 m
514945-000	Joystick harness	1

Table 6-26: SL26/30SL - 514483-000

ELECTRICAL ASSEMBLY - GROUND CONTROL PANEL

PART	DESCRIPTION	QTY
514496-000	Ground control panel	1
514488-000	Ground control enclosure	1
514489-000	Ground control panel overlay	1
3087803	EZcal display	1
510524-000	Twist & release E/stop c/w 1 N/C contact block	1
512543-000	3 position stayput key switch (key removeable only in 1 position) c/w/2 N/O contact blocks	1
510521-000	Deadman toggle switch, on - (on) IP65	1
510522-000	Toggle switch, (on) - off - (on) IP65	1
514132-000	Boot	2
510542-000	Black flush push button c/w 1 N/O contact block	2
512366-000	4 - way panel plug	2
510155-000	3 - way panel plug	1
512817-000	15 - way panel plug	4
510145-000	Mate-N-lock socket contact	50
514622-000	Connector 2 way (crimp pin) panel mount receptacle	2
514626-000	Connector 4 way (crimp pin) panel mount receptacle	1
514624-000	Wedge for 2 way receptacle	2
509750-000	Wedge for 4 way receptacle	1
514627-000	Connector 8 way (crimp pin) panel mount receptacle	1
514629-000	Wedge for 8 - way receptacle	1
509743-000	Connector 12 way (crimp pin) panel mount receptacle	4
509744-000	Wedge for 12 way receptacle	4
100338-013	Crimp pin	48
13485-05	GP400C with SL software	1
13485-03	TBM	1
502588-000	Alarm	1
512934-000	Red LED	1
509740-002	Fuse 10 Amp blade	1
509741-000	Fuse holder	1
510671-000	Cable 1.0 mm CSA	4 m
510645-000	Seal strip	1.2 m

Table 6-27: SL26/30SL - 514487-000

ILLUSTRATED PARTS LIST

ELECTRICAL ASSEMBLY - CABLE ASSEMBLIES

PART	DESCRIPTION	QTY
514608-000	Harness; platform extension SL26	1
514608-001	Harness; platform extension SL30	1
514609-000	Harness; platform SL26	1
514609-001	Harness; platform SL30	1
514610-000	Cable harness CANTILT short link SL26/30	2
514611-000	Cable harness CAN axle float SL26/30	1
514612-000	Cable harness engine SL26/30	1
514613-000	Cable harness Drive manifold SL26/30	1
514614-000	Cable harness lower valve SL26/30	1
514615-000	Cable harness axle float valve SL26/30	1
514616-000	Cable harness movement manifold SL26/30	1
514618-000	Cable harness EZfits SL26/30 CE	1
514618-001	Cable harness EZfits SL26/30 ANSI	1

Table 6-28: SL26/30SL - Cable assemblies

ELECTRICAL ASSEMBLY - EXTERNAL COMPONENTS

PART	DESCRIPTION	QTY
514482-001	CANTILT sensor #1	1
514482-002	CANTILT sensor #2	1
514482-003	CANTILT sensor #3	1
514482-004	CANTILT sensor #4	1
3030157	EZfit	2
501868-001	Horn	1

Table 6-29: SL26/30SL - External components

ILLUSTRATED PARTS LIST

CABLE HARNESS SCHEMATIC - 514481-000

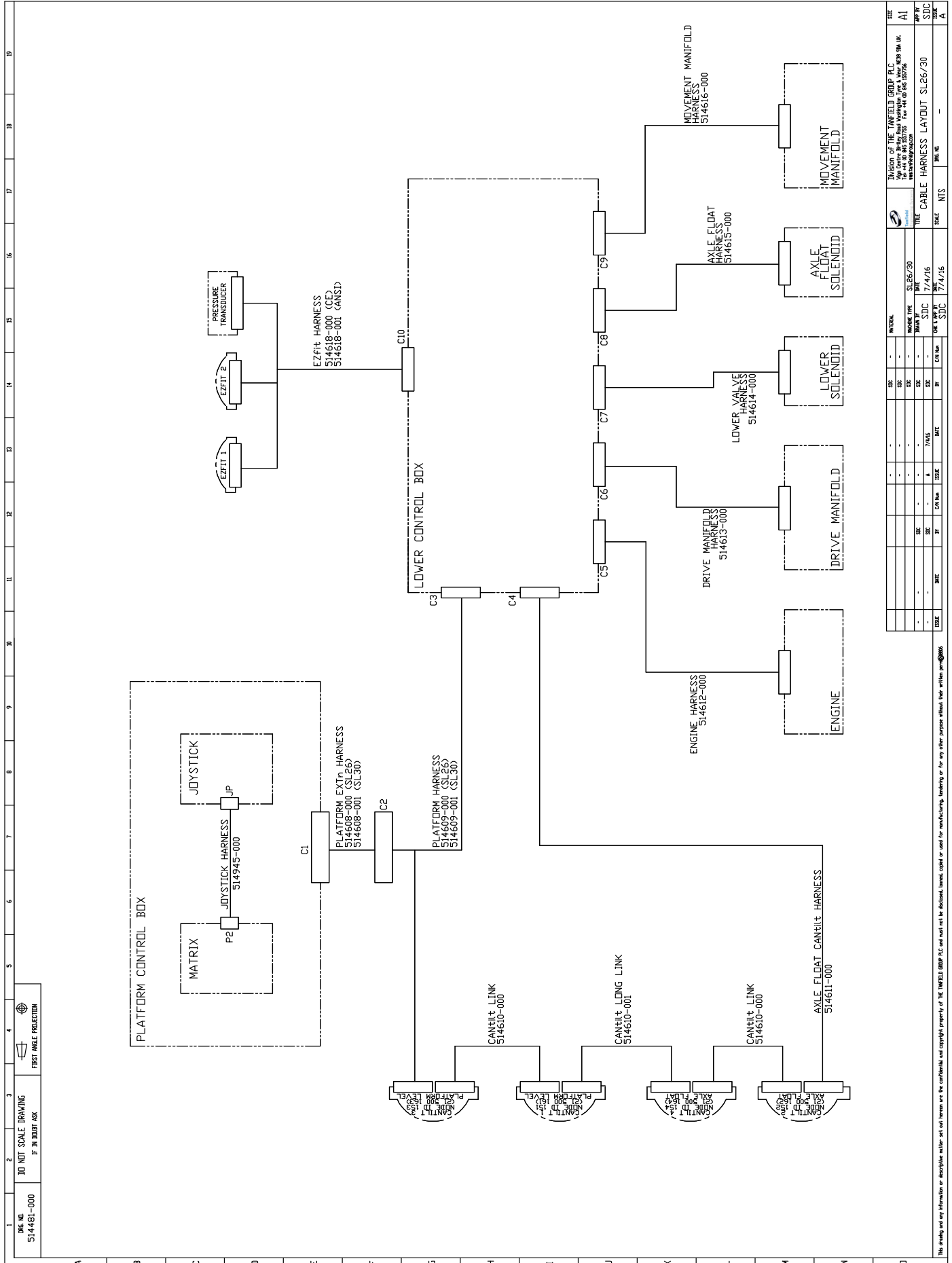

REV	DATE	BY	CHK'D	DATE	BY	CHK'D	DESCRIPTION
1							
2							
3							
4							
5							
6							
7							
8							
9							
10							
11							
12							
13							
14							
15							
16							
17							
18							
19							

REV	DATE	BY	CHK'D	DATE	BY	CHK'D	DESCRIPTION
1							
2							
3							
4							
5							
6							
7							
8							
9							
10							
11							
12							
13							
14							
15							
16							
17							
18							
19							

REV	DATE	BY	CHK'D	DATE	BY	CHK'D	DESCRIPTION
1							
2							
3							
4							
5							
6							
7							
8							
9							
10							
11							
12							
13							
14							
15							
16							
17							
18							
19							

DECAL ASSEMBLY

Figure 6-23: Illustration shows SL30 machine, reference for SL26 decal location

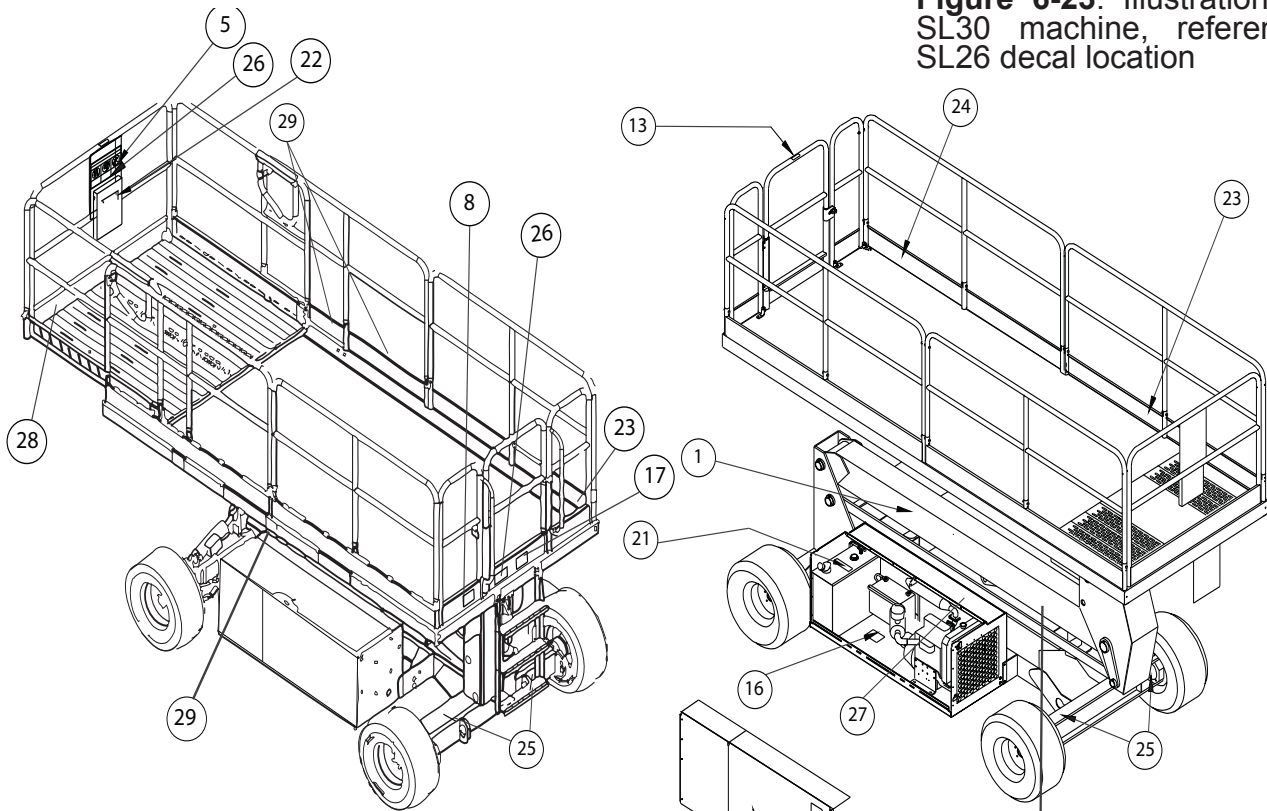

Figure 6-22: SL26, including extension deck decal arrangement

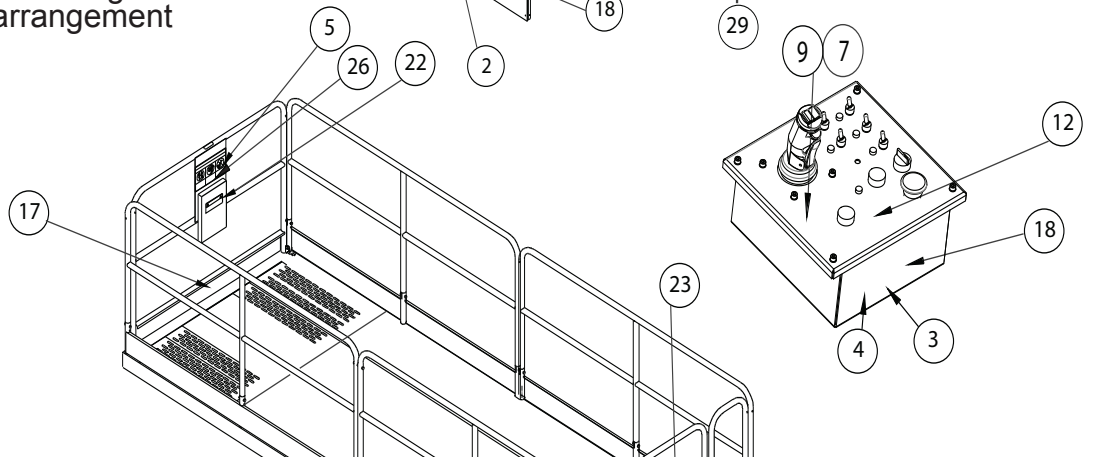
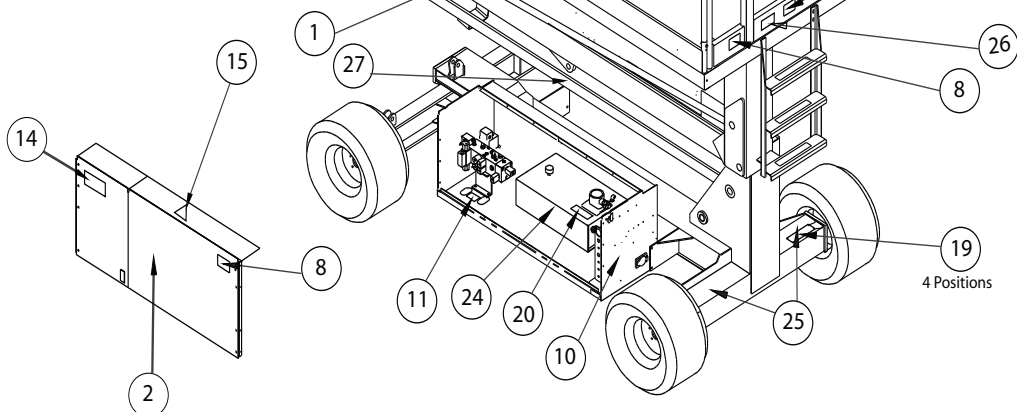

Figure 6-24: Illustration shows SL30 machine, reference for SL26 decal location



ILLUSTRATED PARTS LIST

DECAL KIT SL30SL - ENGLISH

SPEED LEVEL

1 511104-000 qty 2

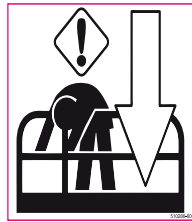

10 510280-000 qty 1

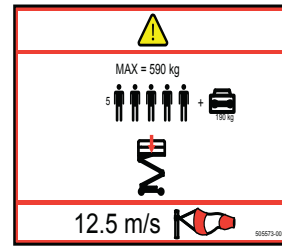

17 505573-001 qty 2

2 511088-000(SL30),qty 2



3 509523-000 qty 1



11 066555-000 qty 1



18 067822-001 qty 2



4 510460-000 qty 1



12 064374-000 qty 1



19 058531-000 qty 4



29 514360-000 qty 4

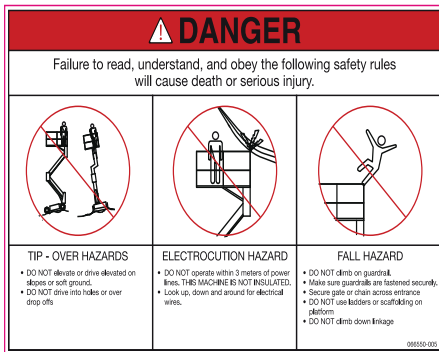

5 066550-005 qty 1



13 066563-000 qty 1

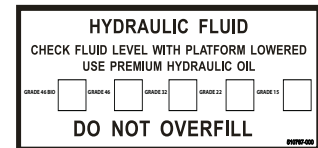

20 510787-000 qty 1



6 508494-000 qty 1



14 101210-000 qty 1



21 027898-001 qty 1

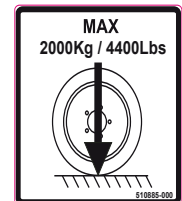

25 510885-000 qty 4



7 066551-003 qty 1



22 010076-901 qty 1



8 066551-002 qty 2



15 066556-900 qty 2

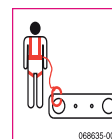

23 068635-001 qty 4

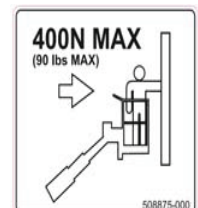

26 508875-000 qty 2



9 066554-000 qty 1



16 057430-002 qty 1



24 302950 qty 1

www.snorkellifts.com

27 511066-000 qty 2

DECAL KIT SL26SL - ENGLISH

SPEED LEVEL

1 511104-000 qty 2

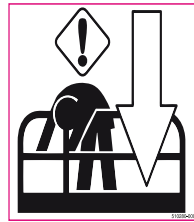

10 510280-000 qty 1

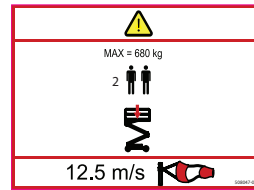

17 508047-001 qty 1

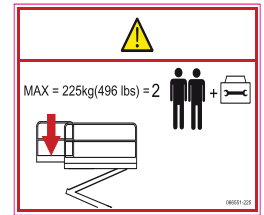

28 066551-225 qty 1

2 511087-000(SL26).qty 2



3 509523-000 qty 1



11 066555-000 qty 1



18 067822-001 qty 2



29 514360-000 qty 4



4 510460-000 qty 1



12 064374-000 qty 1



19 058531-000 qty 4

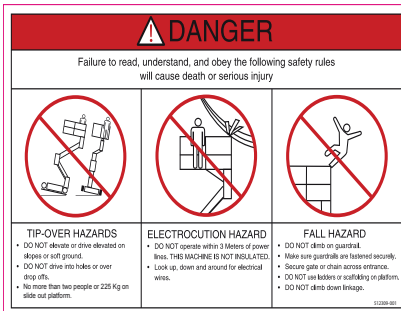

13 066563-000 qty 1

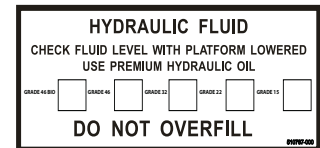

20 510787-000 qty 1

5 512309-001 qty 1



6 508494-000 qty 1



14 101210-000 qty 1



21 027898-001 qty 1

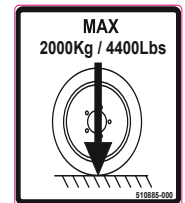

25 510885-000 qty 4



7 066551-003 qty 1



22 010076-901 qty 1



8 066551-002 qty 2



15 066556-900 qty 2

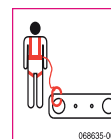

23 068635-001 qty 4

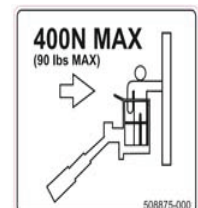

26 508875-000 qty 2



9 066554-000 qty 1



16 057430-002 qty 1

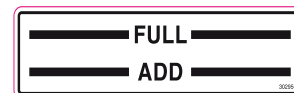

24 302950 qty 1

www.snorkellifts.com

27 511066-000 qty 2

ILLUSTRATED PARTS LIST

DECAL KIT SL30SL - ENGLISH

ITEM	PART	DESCRIPTION	QTY
1	511104-000	Decal, speed level	2
2	511088-000	Decal, Snorkel SL30	2
3	509523-000	Decal, 3 position key (non ANSI)	1
4	510460-000	Decal, hi-low speed SL UCB	1
5	066550-005	Warning	1
6	508494-000	LWA Decal 107 dB	1
7	066551-003	Tipping hazard	1
8	066551-002	Tipping hazard	2
9	066554-000	Caution, read operation manual	1
10	510280-000	Emergency lower	1
11	066555-000	Do not adjust	1
12	064374-000	To level	1
13	066563-000	Distance to ground	1
14	101210-000	Risk of hydrogen gas and battery leakage	1
15	066556-900	Risk from above	1
16	057430-002	Risk of explosion	1
17	505573-001	Safe working load	1
18	067822-001	Attention glow plugs	2
19	058531-000	Lift/tie down point	4
20	510787-000	Hydraulic fluid	1
21	027898-001	Diesel fuel	1
22	010076-901	Decal, attention documents enclosed	1
23	068635-001	Harness anchor point	4
24	302950	Decal, hydraulic oil level minimum/maximum	1
25	508875-000	Decal, side force 400 N	2
26	510885-000	Decal, wheel loading	4
27	511066-000	Decal, web address	2
29	514360-000	Finger trap decal	4

Table 6-30: SL26/30SL - 510876-000

DECAL KIT SL26SL - ENGLISH

ITEM	PART	DESCRIPTION	QTY
1	511104-000	Decal, speed level	2
2	511087-000	Decal, Snorkel SL26	2
3	509523-000	Decal, 3 position key (non ANSI)	1
4	510460-000	Decal, hi-low speed SL UCB	1
5	512309-001	Warning	1
6	508494-000	LWA Decal 107 dB	1
7	066551-003	Tipping hazard	1
8	066551-002	Tipping hazard	2
9	066554-000	Caution, read operation manual	1
10	510280-000	Emergency lower	1
11	066555-000	Do not adjust	1
12	064374-000	To level	1
13	066563-000	Distance to ground	1
14	101210-000	Risk of hydrogen gas and battery leakage	1
15	066556-900	Risk from above	1
16	057430-002	Risk of explosion	1
17	508047-001	Safe working load	2
18	067822-001	Attention glow plugs	2
19	058531-000	Lift/tie down point	4
20	510787-000	Hydraulic fluid	1
21	027898-001	Diesel fuel	1
22	010076-901	Decal, attention documents enclosed	1
23	068635-001	Harness anchor point	4
24	302950	Decal, hydraulic oil level minimum/maximum	1
25	508875-000	Decal, side force 400 N	2
26	510885-000	Decal, wheel loading	4
27	511066-000	Decal, web address	2
28	066551-225	Decal, safe working load extension deck	
29	514360-000	Finger trap decal	4

Table 6-31: SL26/30SL - 508083-000

**Local Distributor / Lokaler Vertiebshändler / Distributeur local
El Distribuidor local / Il Distributore locale**

**EUROPE, MIDDLE EAST
AFRICA & ASIA**

PHONE: +44 (0) 845 1550 057
FAX: +44 (0) 845 1557 756

NORTH & SOUTH AMERICA

PHONE: +1 785 989 3000
TOLL FREE: +1 800 225 0317
FAX: +1 785 989 3070

AUSTRALIA

PHONE: +61 2 9725 4000
FAX: +61 2 9609 3057

NEW ZEALAND

PHONE: +64 6 3689 168
FAX: +64 6 3689 164

 **snorkel**
www.snorkellifts.com